

MODEL MINI-1 GLYCOL CIRCULATOR

PERFECTION



Perfection Equipment, Inc.
Perfecta Stainless Division



LINE RUNS

- Up to 100 feet
- Multiple dispensing locations

CONSTANT RUNNING COMPRESSOR

- Longer compressor life
- Self-Starting after power failure

REFRIGERATION SYSTEM

Includes a 1/3 horsepower continuous running compressor. An externally equalized thermostatic expansion valve (TXV) controls the flow of liquid refrigerant into the evaporator. A hot gas bypass valve (HGB) controls the refrigerant affect and adjusts the unit's horsepower to the load.

COOLANT SYSTEM

The Coolant System consists of a water/glycol mixture of 2/1 with a reservoir tank incorporated within the unit to hold a small percentage of coolant. A 60 GPH brass pump draws the coolant from the bottom of the tank and propels it into the chiller coil. The coolant exits the coil and goes directly to the line run. Upon return from the line run the coolant goes directly to the reservoir tank completing the cycle.

SERVICE AND INSTALLATION

Available from a national network of trained and authorized technicians.

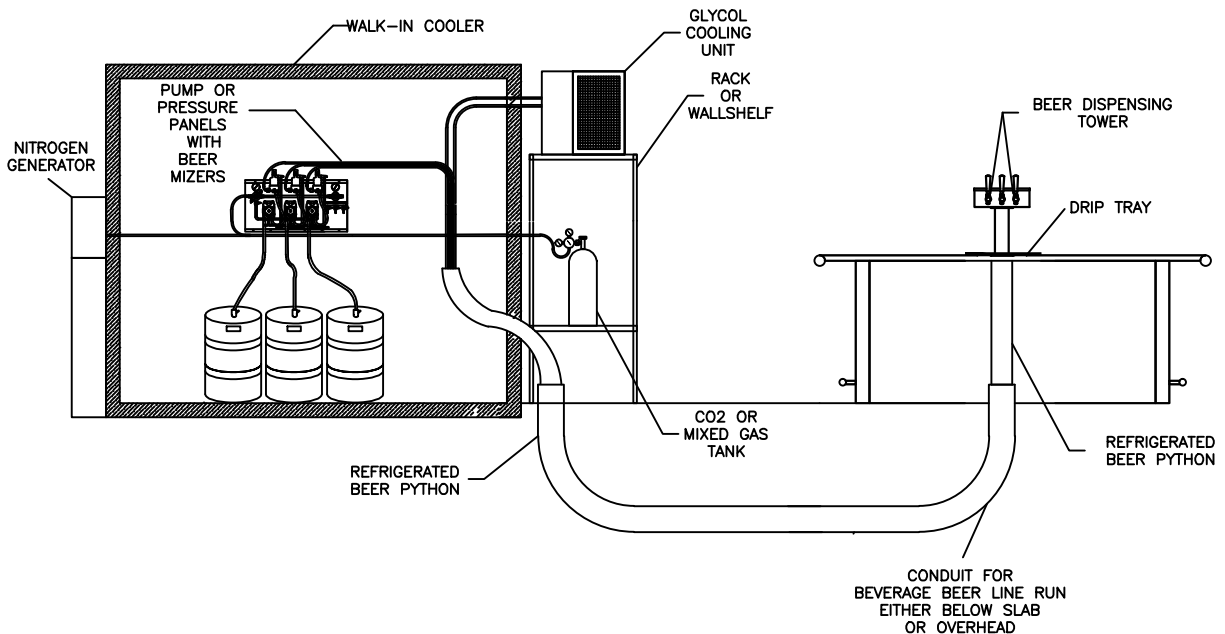

PERFECTION Equipment, Inc.

4259 Lee Avenue, Gurnee, Illinois 60031, Phone: 847-244-7200, Fax: 847-244-7205, Toll Free: 800-356-6301
Website: www.perfectequip.com Mail to: sales@perfectequip.com



**MODEL MINI-1 GLYCOL
CIRCULATOR**

PERFECTION



Perfection Equipment, Inc.
Perfecta Stainless Division

**MODEL MINI-1
AVAILABLE IN AIR-COOLED
115V**

SPECIFICATIONS

VENTILATION / AIR-COOLED UNIT(S): REQUIRED VENTILATION PROVIDED BY OTHERS NEEDS TO ENSURE THAT THE TEMPERATURE WHERE THE UNIT(S) ARE LOCATED **DOES NOT EXCEED 85°F**. SIZE VENTILATION SYSTEM FOR EACH UNIT(S) BASED ON BTU'S FOR THE MODEL BELOW:

1/3 H.P. MINI-1

GLYCOL CHILLER

HEAT OF REJECTION 3802 BTU / HR

ELECTRICAL: DEDICATED CIRCUIT(S) FOR EACH UNIT (S) TO BE PROVIDED BY OTHERS BASED ON THE MODEL BELOW:

1/3 H.P. MINI-1

115V

AIR- COOLED

60 HZ, SINGLE PHSE 20.0 AMP

RLA 5.8

MCA 13.4

SHIPPING DIMENSIONS: 30" X 17" X 13"

SHIPPING WEIGHT: 90 lbs.

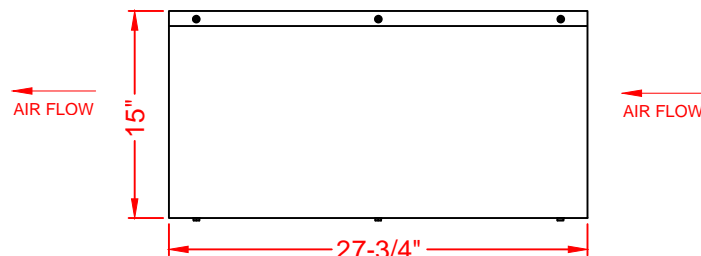

TOP VIEW

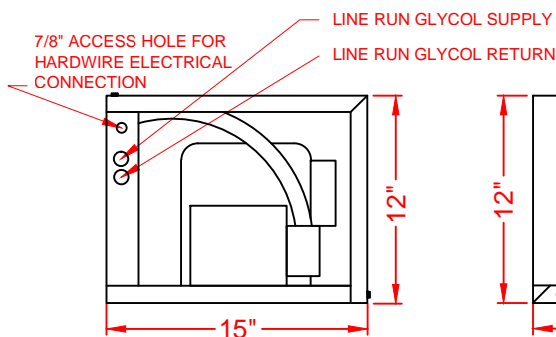

LEFT SIDE VIEW

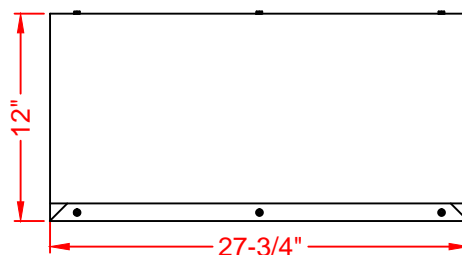

FRONT VIEW

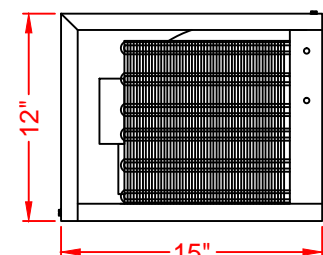

RIGHT SIDE VIEW



PERFECTION Equipment, Inc.

4259 Lee Avenue, Gurnee, Illinois 60031, Phone: 847-244-7200, Fax: 847-244-7205, Toll Free: 800-356-6301
Website: www.perfectequip.com Mail to: sales@perfectequip.com

