

PERFECTION BY DESIGN

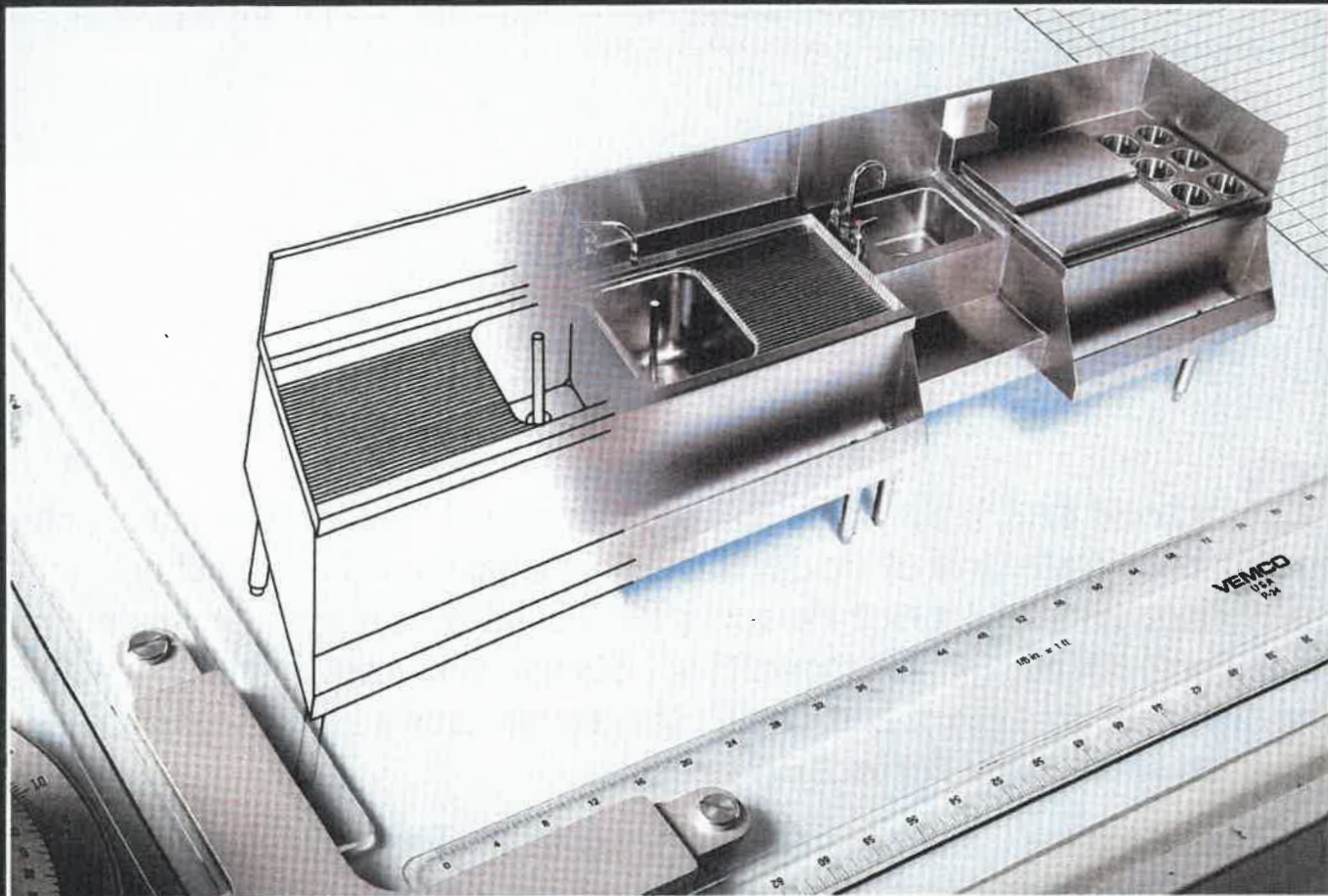

Consultant Underbar Series

Newly perfected. At the moment when Perfection Equipment created the Perfecta underbar line, a pledge of design excellence was formed. This is our commitment. This is our design. This is the Consultant series.

Perfecta underbars are created for design consultants who require the best. Our custom construction is crafted from only

18 gauge 304-18-8 No. 4 stainless steel for strength. The corrugated, seamless, pitched top stands unmatched for quality in the industry.

Whatever your underbar needs, from the optional gold-electroplated details or mirror finish, with the Consultant series, you can rest assured each underbar has been designed to impeccable standards.



PERFECTION Equipment, Inc.

Perfecta Stainless Division

4259 Lee Ave. • Gurnee, Illinois 60031

Phone: 708/244-7200 • Toll-free: 1-800/356-6301

When custom quality counts, why risk anything less than Perfecta?

PERFECTA PF-22 and PF-19
Underbar Series

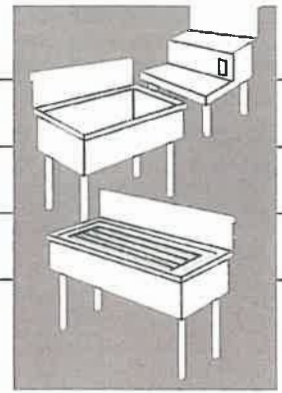

Designed and built with the user in mind, Perfection offers the most complete line of underbar equipment available today. Whether you select our Perfecta PF-22 "Consultant" Series or our Perfecta PF-19 "Competitive" Series, you can be certain your equipment has been built with the same care and experience that go into every Perfection product.

Whatever your underbar needs, look to Perfecta by Perfection and remember . . . Perfection is not just our name . . . it is our commitment.



PERFECTION Equipment, Inc.

4259 Lee Avenue, Gurnee, Illinois 60031 Phone: 847-244-7200 Fax: 847-244-7205
Website: www.perfectequip.com Email: sales@perfectequip.com

Toll Free: 800-356-6301

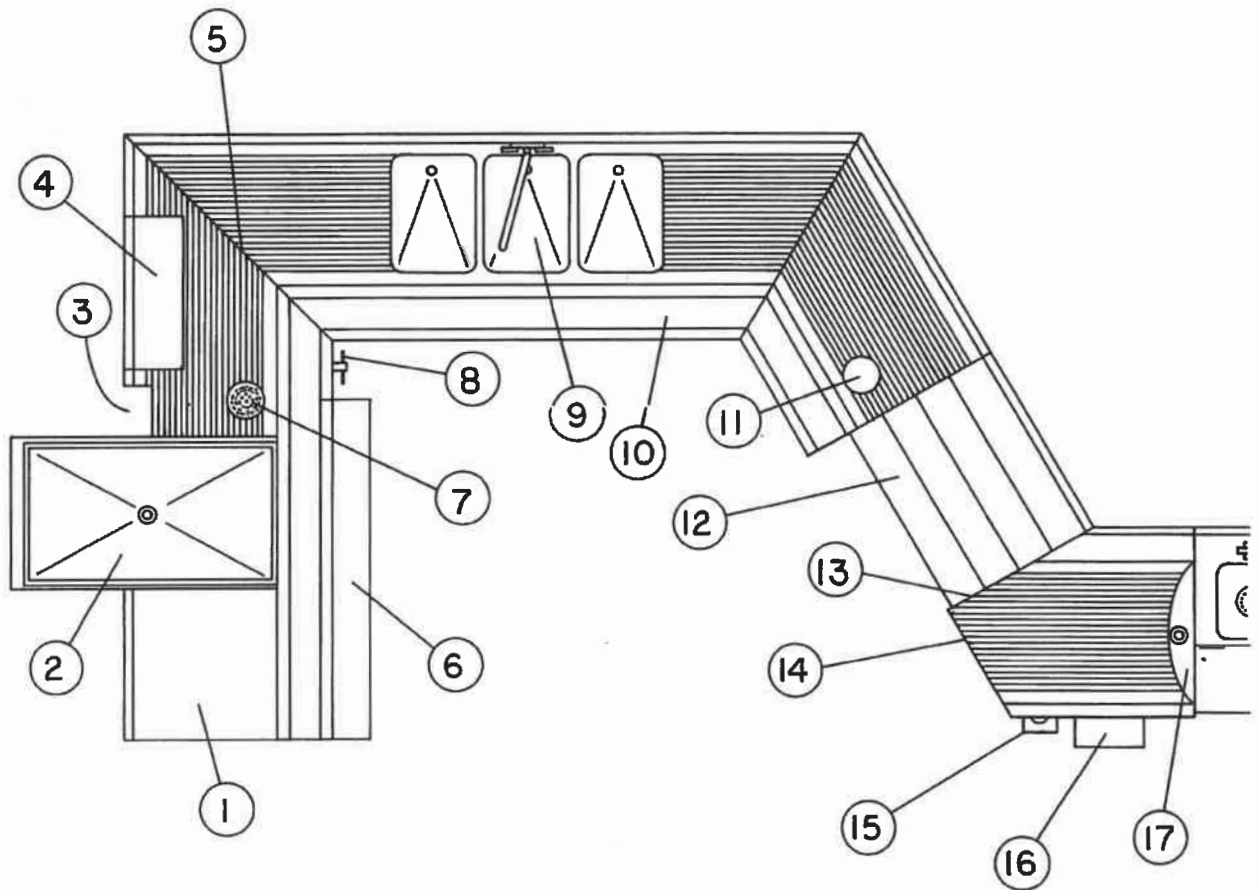

- 1. FLAT S/S TOP
- 2. ICE CHEST TURNED 90°
- 3. SODA/BEER CUT-OUT
- 4. GLASS SHELF
- 5. MITER WITH BUILT-IN SPEEDRAIL
- 6. HANG-ON SPEEDRAIL FOR FRONT OF BUILT-IN SPEEDRAIL
- 7. WET WASTE CHUTE WITH PERFORATED BASKET
- 8. S/S TOWEL RING

- 9. TRIPLE RINSE TANKS
- 10. BUILT-IN SPEEDRAIL
- 11. DRY WASTE CHUTE (WORKBOARD MOUNTED)
- 12. LIQUOR STEP DISPLAY
- 13. PARTIAL CLIP
- 14. FULL CLIP
- 15. BOTTLE OPENER WITH CAP CATCH
- 16. DRY WASTE CHUTE (APRON MOUNTED)



PERFECTION Equipment, Inc.

4259 Lee Avenue, Gurnee, Illinois 60031 Phone: 847-244-7200 Fax: 847-244-7205
 Website: www.perfectequip.com Email: sales@perfectequip.com

Toll Free: 800-356-6301



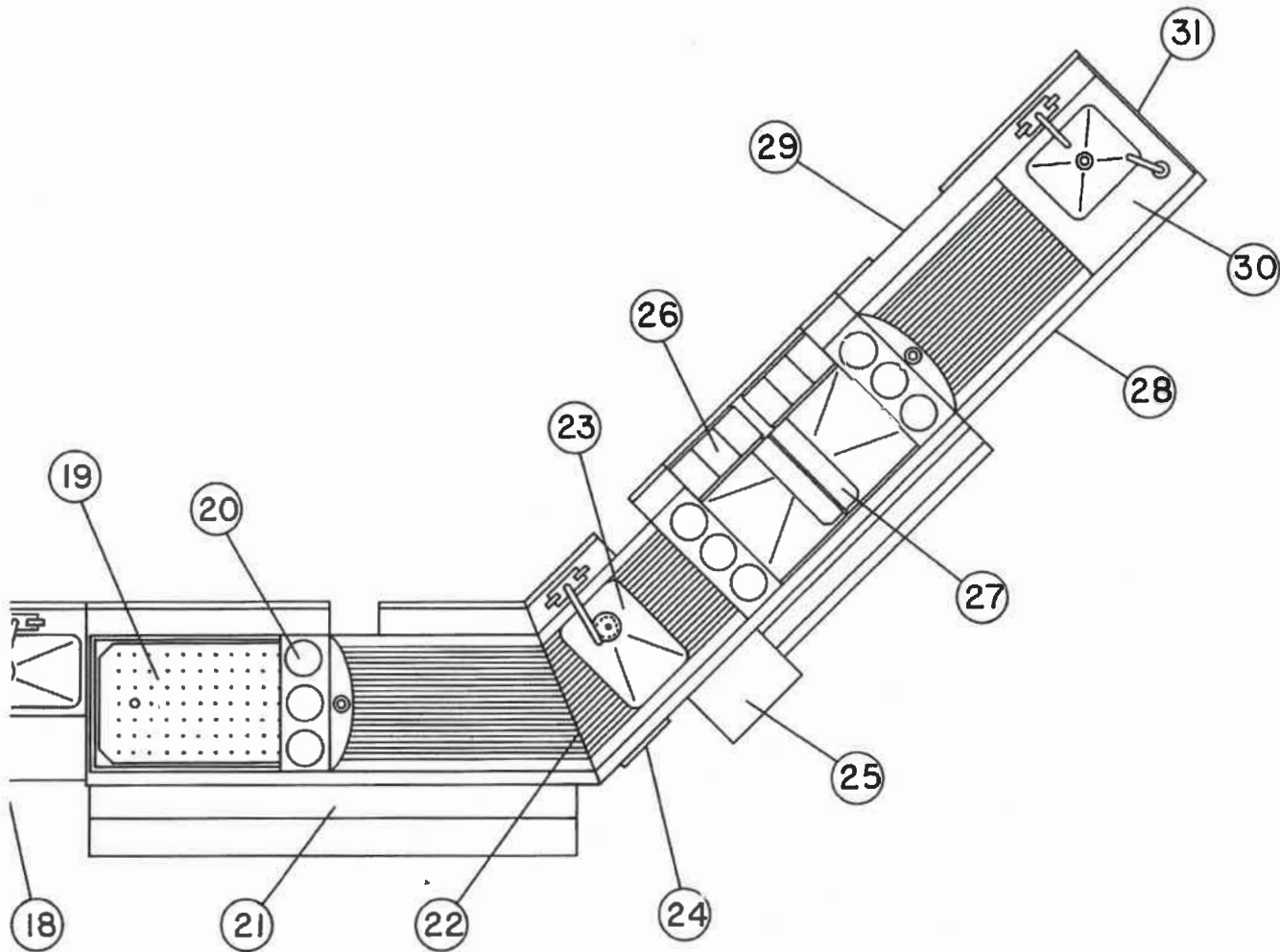

- 17. CORRUGATION DRAIN
- 18. MIXER/BLENDER SHELF WITH DUMP SINK
- 19. 30" ICE CHEST WITH PERFORATED BOTTOM INSERT
- 20. S/S BOTTLEWELLS
- 21. DOUBLE HANG-ON SPEEDRAIL
- 22. MITER WITHOUT BUILT-IN SPEEDRAIL
- 23. DUMP SINK
- 24. S/S TOWEL BAR

- 25. 12" HANG-ON BLENDER SHELF
- 26. CONDIMENT WELLS
- 27. 36" ICE CHEST WITH ICE DIVIDER
- 28. APRON CUT-OUT
- 29. BACKSPLASH CUT-OUT
- 30. HAND SINK
- 31. END SPLASH



PERFECTION Equipment, Inc.

4259 Lee Avenue, Gurnee, Illinois 60031 Phone: 847-244-7200 Fax: 847-244-7205
 Website: www.perfectequip.com Email: sales@perfectequip.com

Toll Free: 800-356-6301



**PERFECTA PHS-22 and PHS-19
Handsinks
and PHS-15 Wallmount Sink**

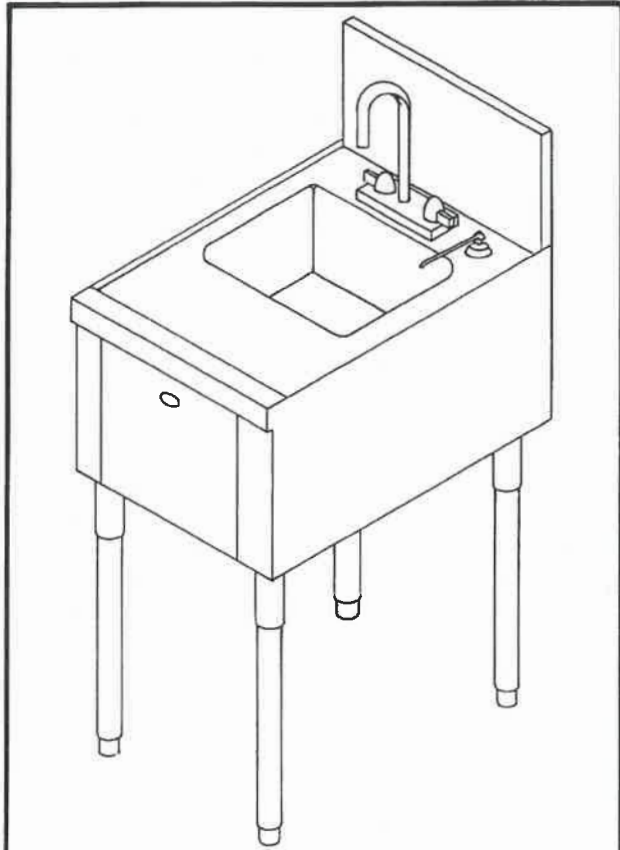
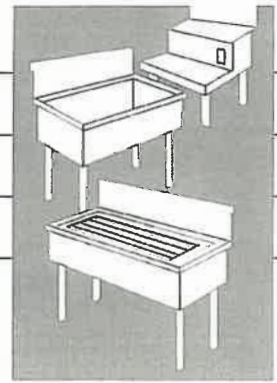

MODEL PHS-22

- Type 304 all stainless steel construction.
- Will dispense C-Fold or Multi-Fold handtowels.
- Faucet, deck mounted.
- 3½" Strainer drain included.
- Liquid soap dispenser included.
- Can be incorporated as an integral part of a workboard-cocktail unit lineup.
- Unit size: 38" high, 15½" wide and 22½" deep*
- Sink size: 11¾" long x 9½" wide x 6" deep.

*Model PHS-19 same as PHS-22 except:
Unit depth, 19½"
Standard faucet provided

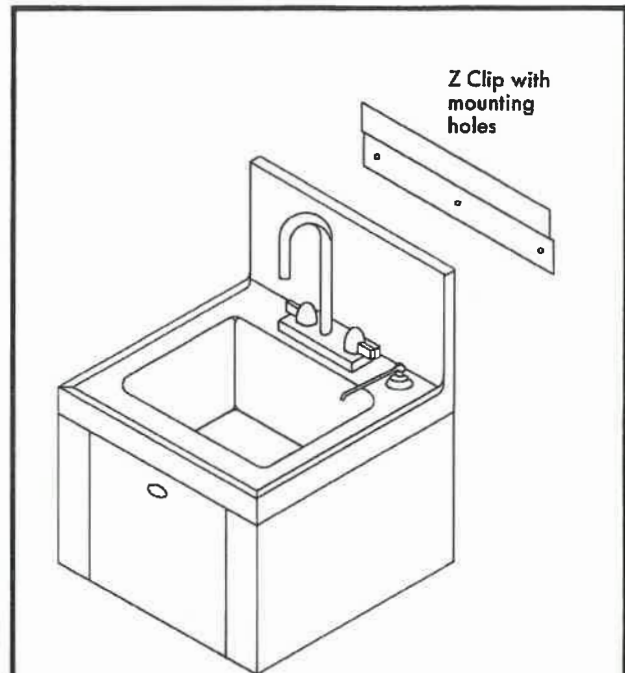

MODEL PHS-15

- Type 304 all stainless steel construction.
- Will dispense C-Fold or Multi-Fold handtowels.
- Faucet, deck mounted.
- 3½" Strainer drain included.
- Liquid soap dispenser included.
- Unit size: 20" high, 15½" wide and 15½" deep.
- Sink size: 11¾" long x 9½" wide x 6" deep.
- Available as wallmount only.



PERFECTION Equipment, Inc.

4259 Lee Avenue, Gurnee, Illinois 60031 Phone: 847-244-7200 Fax: 847-244-7205
Website: www.perfectequip.com Email: sales@perfectequip.com

Toll Free: 800-356-6301



SPECIFICATIONS

HANDSINKS

Model PHS-22 and PHS-19

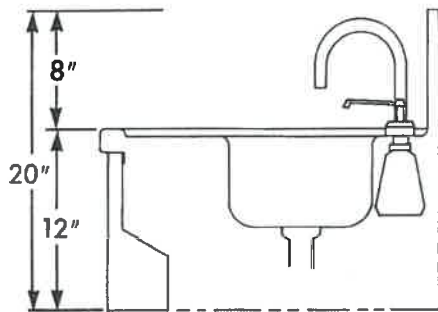
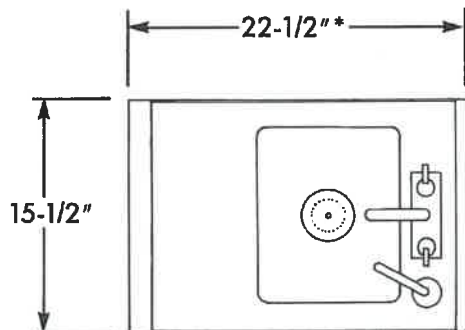
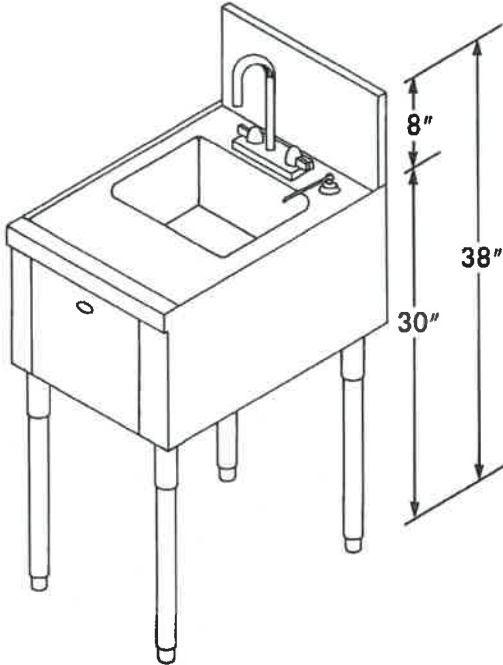

*Model HS-PF19—19-1/2"

Model PHS-15 (Wallmount Only)

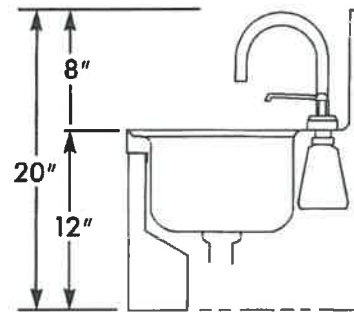
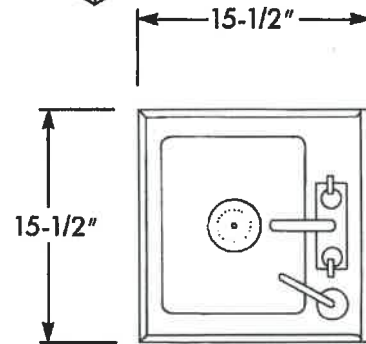
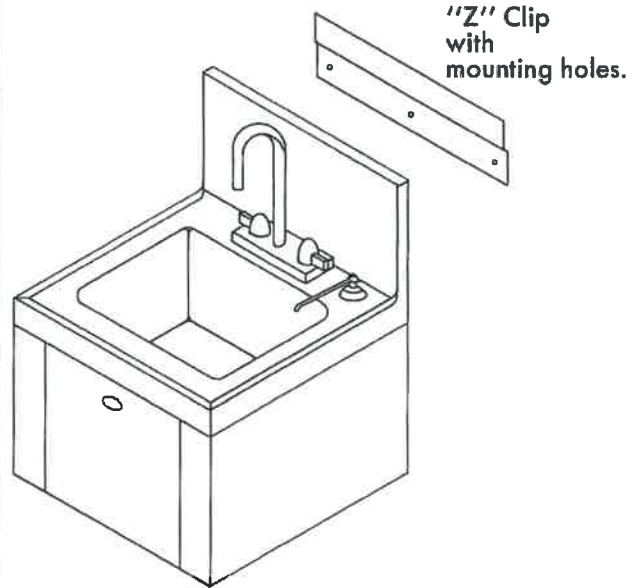

PERFECTION Equipment, Inc.

4259 Lee Avenue, Gurnee, Illinois 60031 Phone: 847-244-7200 Fax: 847-244-7205
Website: www.perfectequip.com Email: sales@perfectequip.com

Toll Free: 800-356-6301



PERFECTA PF-22 and PF-19 Display and Storage Units

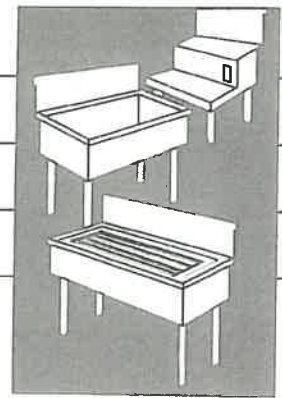

2900

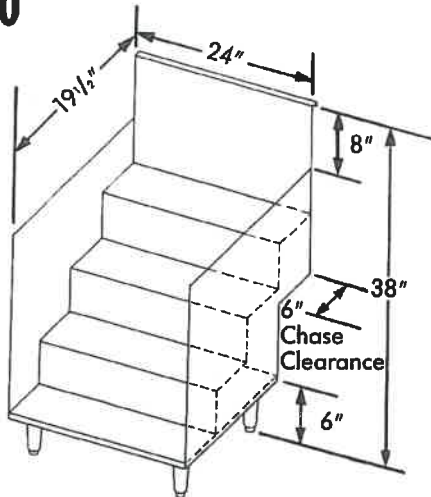

24" Four (4) shelf liquor display stand
(equivalent to 8' 0" of speedrail).

**Optional Locking
Self-Contained Cover
Available — Contact
Factory for Changes
in Dimensions**

2930 or 2948

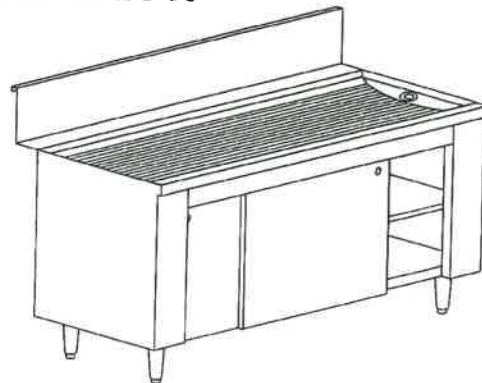

30" Storage cabinet includes corrugated top with drain, 6" adjustable legs, sliding doors, shelves and backing. (Also available as flat top workboard.)

48" Storage cabinet includes corrugated top with drain, 6" adjustable legs, sliding doors, shelves and backing. (Also available as flat top workboard.)

2910

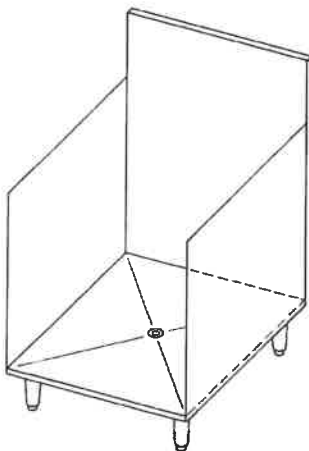

24" Glass storage stand with drain.



PERFECTION Equipment, Inc.

4259 Lee Avenue, Gurnee, Illinois 60031 Phone: 847-244-7200 Fax: 847-244-7205
Website: www.perfectequip.com Email: sales@perfectequip.com

Toll Free: 800-356-6301

NSF

PERFECTA PF-19

Competitive Series

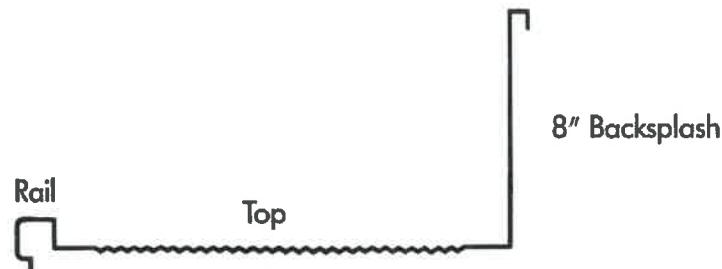
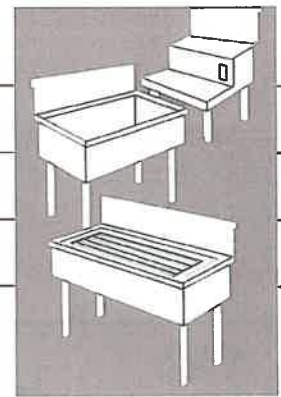

UNIQUE ONE-PIECE TOP

DRAINBOARD TOP

- Fully heliarc welded one-piece construction* with front rail, top working surface and backsplash die formed from one sheet of 18 gauge type 304-18-8 stainless steel with #4 finish.
- Apron and both ends of 18 Gauge type 304-18-8 stainless steel with #4 finish.
- Corrugated areas are "pitched" to rinse tank or drain area (optional surface drain available on sections less than 18" in length.
- All corrugations are $\frac{3}{32}$ " deep with (3) three corrugations to the inch.
- Tops are reinforced with multiple 16 Gauge stainless steel "U" channel.
- All undersurfaces are mastic coated for noise and vibration dampening.

*Seams will occur at miters and on straight sections in excess of 9' 8" in length.

RINSE TANK

- 10" x 14" x 9 $\frac{3}{4}$ " deep.
- Seamless.
- One-piece, die-stamped construction with 2" radii on all vertical and horizontal corners.
- 18 Gauge type 304-18-8 stainless steel.
- Heliarc welded, ground and polished at top.

ICE CHEST

- (3) Three standard sizes to choose from:
24" (inner liner dimensions 22" x 16" x 10" deep)
30" (inner liner dimensions 28" x 16" x 10" deep)
36" (inner liner dimensions 34" x 16" x 10" deep)
- $\frac{1}{2}$ " Radii on all vertical and horizontal corners.
- Mastic coated ice chest liner, fully insulated.
- Top perimeter has $\frac{3}{8}$ " raised edge.
- Other sizes available including 16" deep units.
- Sealed-in, seven-circuit cold plate available with bump fittings for inlet and outlet lines.

FRAME

- All framing members are 16 Gauge type 304-18-8 stainless steel.
- All top and bottom edges are "L" shaped.
- Corner support members and leg sockets are heliarc welded into place.

LEGS

- 1 $\frac{5}{8}$ " O.D. Diameter.
- 16 Gauge stainless steel with adjustable stainless steel bullet feet.
- Leg sockets are constructed of 16 Gauge stainless steel with locking set screw. Heliarc welded to 16 Gauge stainless steel support channels.



PERFECTION Equipment, Inc.

4259 Lee Avenue, Gurnee, Illinois 60031 Phone: 847-244-7200 Fax: 847-244-7205
Website: www.perfectequip.com Email: sales@perfectequip.com

Toll Free: 800-356-6301



Series PF 19-2000, PF 19-2010, PF 19-2050 and PF 19-2060

Series PF 19-2000 Straight Underbar Workboard

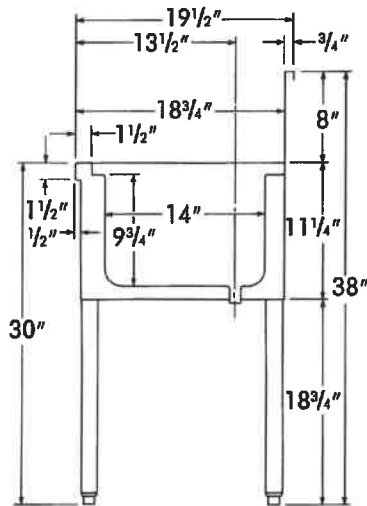

- Stainless steel apron, corrugated worktop and backsplash.

Series PF 19-2010 Underbar Workboard (same as 19-2000 plus)

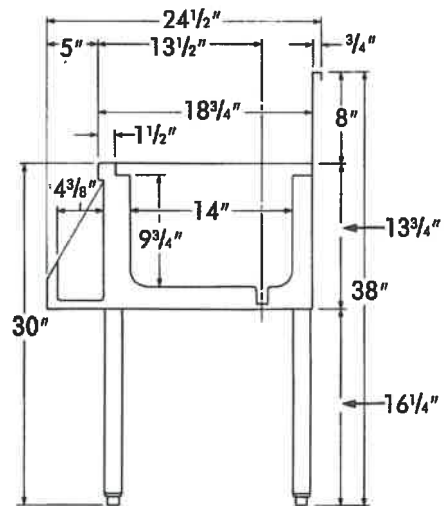

- Built-in bottle speedrail.

Series PF 19-2050 Underbar Workboard (same as 19-2000 plus)

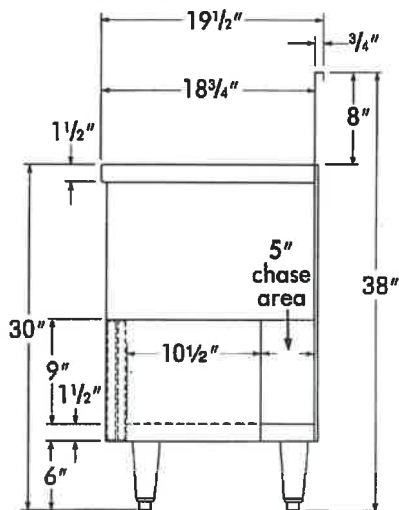

- Built-in cabinet base.
- 6" adjustable legs and stainless steel sliding doors.
- Base has open chase at back for plumbing and wiring connections.

Series PF 19-2060 Underbar Workboard (same as 19-2010 plus)

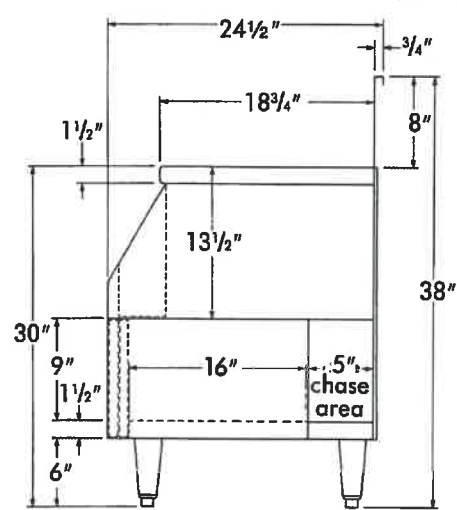

- Built-in cabinet base.
- 6" adjustable legs and stainless steel sliding doors.
- Base has open chase at back for plumbing and wiring connections.



PERFECTION Equipment, Inc.

4259 Lee Avenue, Gurnee, Illinois 60031 Phone: 847-244-7200 Fax: 847-244-7205
 Website: www.perfectequip.com Email: sales@perfectequip.com

Toll Free: 800-356-6301



PERFECTA PF-22 Consultant Series

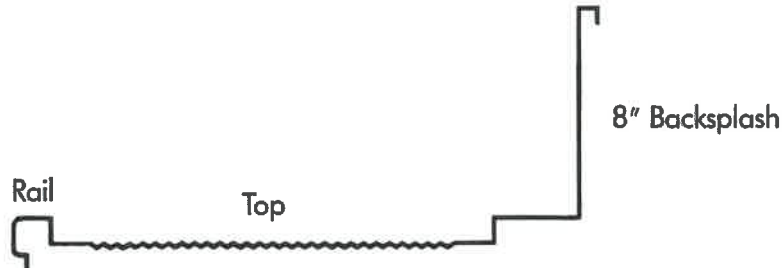
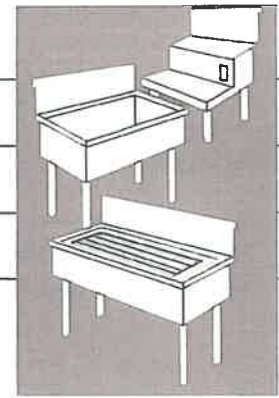

UNIQUE ONE-PIECE TOP

DRAINBOARD TOP

- Fully heliarc welded one-piece construction* with front rail, top working surface and backsplash die-formed from one sheet of 18 gauge type 304-18-8 stainless steel with #4 finish.
- Apron and both ends of 18 gauge type 304-18-8 stainless steel with #4 finish.
- Corrugated areas are "pitched" to rinse tank or drain area (optional surface drain available on sections less than 18" in length).
- All corrugations are $\frac{3}{32}$ " deep with (3) three corrugations to the inch.
- Tops are reinforced with multiple 16 Gauge stainless steel "U" channel.
- All undersurfaces are mastic coated for noise and vibration dampening.

*Seams will occur at miters and on straight sections in excess of 9'8" in length.

RINSE TANK

- 10" x 14" x 9 $\frac{3}{4}$ " deep.
- Seamless.
- One-piece, die-stamped construction with 2" radii on all vertical and horizontal corners.
- 18 Gauge type 304-18-8 stainless steel.
- Heliarc welded, ground and polished at top.

ICE CHEST

- (3) Three standard sizes to choose from:
24" (inner liner dimensions 22" x 16" x 10" deep)
30" (inner liner dimensions 28" x 16" x 10" deep)
36" (inner liner dimensions 34" x 16" x 10" deep)
- $\frac{1}{2}$ " Radii on all vertical and horizontal corners.
- Mastic coated ice chest liner, fully insulated.
- Top perimeter has $\frac{3}{8}$ " raised edge.
- Other sizes available including 16" deep units.
- Sealed-in, seven-circuit cold plate available with bump fittings.

FRAME

- All framing members are 16 Gauge type 304-18-8 stainless steel.
- All top and bottom edges are "L" shaped.
- Corner support members and leg sockets are heliarc welded into place.

LEGS

- 1 $\frac{5}{8}$ " Diameter.
- 16 Gauge stainless steel with adjustable stainless steel bullet feet.
- Leg sockets are constructed of 16 Gauge stainless steel with locking set screw. Heliarc welded to 16 Gauge stainless steel support channels.



PERFECTION Equipment, Inc.

4259 Lee Avenue, Gurnee, Illinois 60031 Phone: 847-244-7200 Fax: 847-244-7205
Website: www.perfectequip.com Email: sales@perfectequip.com

Toll Free: 800-356-6301



Series PF 22-2000, PF 22-2010, PF 22-2050 and PF 22-2060

Series PF 22-2000 Straight Underbar Workboard

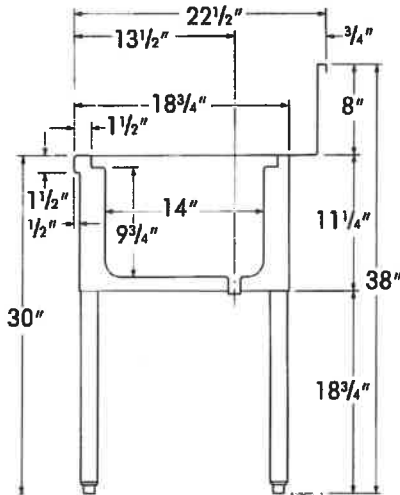

- Stainless steel apron, corrugated worktop, backdeck and 8" backsplash.
- Seamless rinse tanks, stand pipes, drain sockets, legs.
- Ice chest (when specified).

Series PF 22-2010 Underbar Workboard (same as 22-2000 plus)

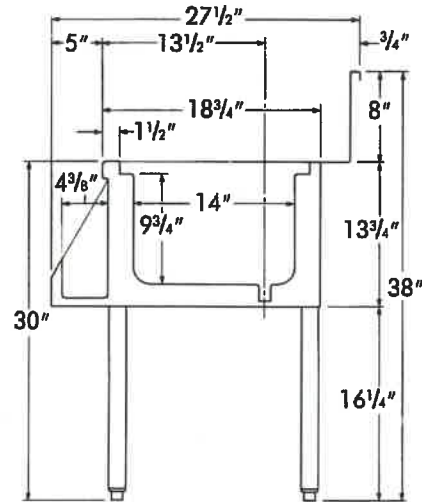

- Built-in bottle speedrail.

Series PF 22-2050 Underbar Workboard (same as 22-2000 plus)

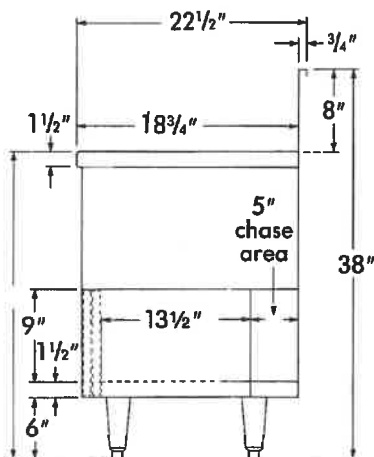

- Built-in cabinet base.
- 6" adjustable legs and stainless steel sliding doors.
- Base has open chase at back for plumbing and wiring connections.

Series PF 22-2060 Underbar Workboard (same as 22-2010 plus)

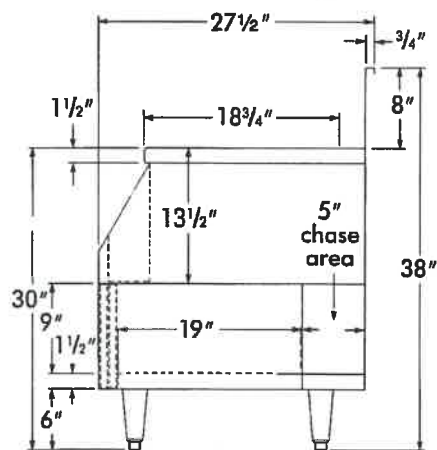

- Built-in cabinet base.
- 6" adjustable legs and stainless steel sliding doors.
- Base has open chase at back for plumbing and wiring connections.



PERFECTION Equipment, Inc.

4259 Lee Avenue, Gurnee, Illinois 60031 Phone: 847-244-7200 Fax: 847-244-7205
 Website: www.perfectequip.com Email: sales@perfectequip.com

Toll Free: 800-356-6301

NSF

PERFECTA PF-22 and PF-19

Mitters, Clips and Field Joints

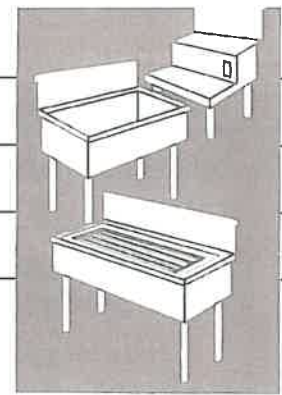

MITERS

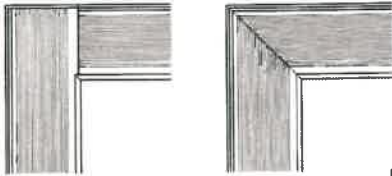

UNIT NO.

Miter workboard (on pipe legs) with stainless steel apron	2100
Miter workboard with built-in bottle speedway (on pipe legs)	2102
Miter workboard with double built-in bottle speedway (on pipe legs)	2104
Miter workboard with cabinet base stainless steel front apron	2106
Miter workboard with cabinet base and built-in bottle speedway	2108
Miter workboard with cabinet base and double built-in bottle speedway	2110

FIELD JOINTS

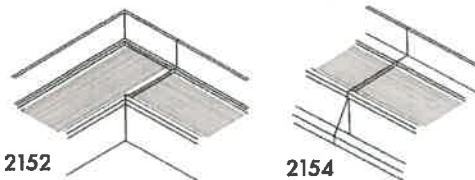

UNIT NO.

Field joint workboard—when joining ends of workboards	2150
Same as 2150—except workboards are not meeting end to end	2152
Field joint workboard with built-in bottle speedway when joining ends of workboards	2154
Same as 2154—except workboards are not meeting end to end	2156
Field joint workboard with double built-in bottle speedway	2158

CLIPS

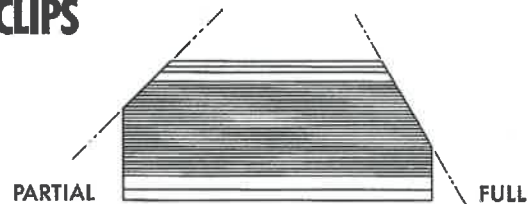

UNIT NO.

Clip workboard corner (on pipe legs)	
Partial clip	2120
Full clip	2122
Clip workboard corner with built-in bottle speedway (on pipe legs)	
Partial clip	2124
Full clip	2126
Clip workboard corner with double built-in bottle speedway (on pipe legs)	
Partial clip	2128
Full clip	2130
Clip workboard corner with cabinet base	
Partial clip	2132
Full clip	2134
Clip workboard corner with cabinet base and built-in bottle speedway	
Partial clip	2136
Full clip	2138
Clip workboard corner with cabinet base and double built-in bottle speedway	
Partial clip	2140
Full clip	2142



PERFECTION Equipment, Inc.

4259 Lee Avenue, Gurnee, Illinois 60031 Phone: 847-244-7200 Fax: 847-244-7205
 Website: www.perfectequip.com Email: sales@perfectequip.com

Toll Free: 800-356-6301



PERFECTA PF-22 and PF-19

Miscellaneous Accessories for Workboard

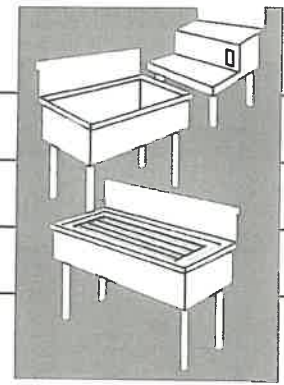

MISCELLANEOUS ACCESSORIES FOR WORKBOARD

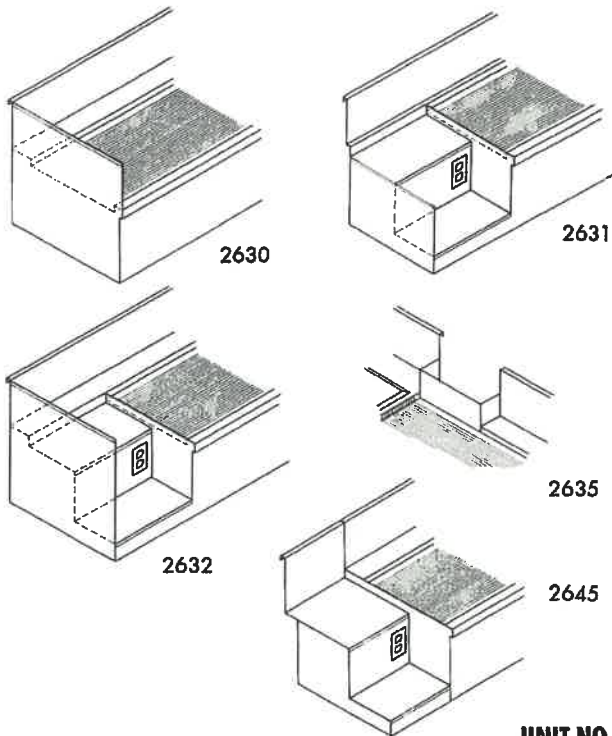

UNIT NO.

- End Splash (same height as backsplash) **2630**
- End Splash for mixer station drop down (step only) **2631**
- Complete end splash for mixer station drop down **2632**
- Soda/beer cutout (when cutting back deck only) 6" x 4" x 4" high **2635**
- Stainless steel end workboard on pipe legs **2640**
- Stainless steel end workboard with cabinet base **2641**
- 12" Mixer Station drop down with duplex outlet **2645**
- 18" Mixer Station drop down with duplex outlet **2646**

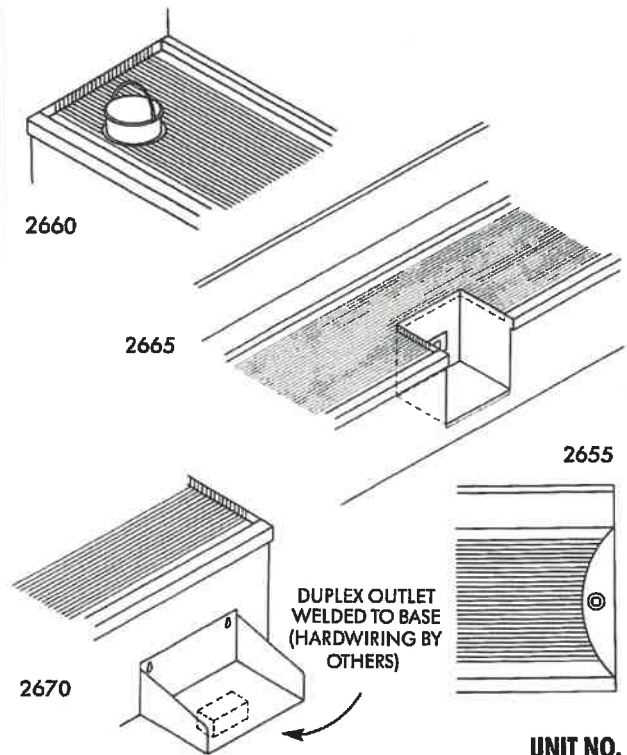

UNIT NO.

- 24" Mixer Station drop down with duplex outlet **2647**
- Corrugation drain utilized in area not drained to rinse tanks. (If corrugation is 20" or less, drain not required) **2655**
- Wet waste chute with perforated lift-out basket **2660**
- 8" x 10" Built-in Blender drop down with duplex outlet **2665**
- 18" x 10" Built-in Blender drop down with duplex outlet **2666**
- 24" x 10" Built-In Blender drop down with duplex outlet **2668**
- Blender shelf with duplex outlet which attaches to front of apron **2670**



PERFECTION Equipment, Inc.

4259 Lee Avenue, Gurnee, Illinois 60031 Phone: 847-244-7200 Fax: 847-244-7205
 Website: www.perfectequip.com Email: sales@perfectequip.com

Toll Free: 800-356-6301



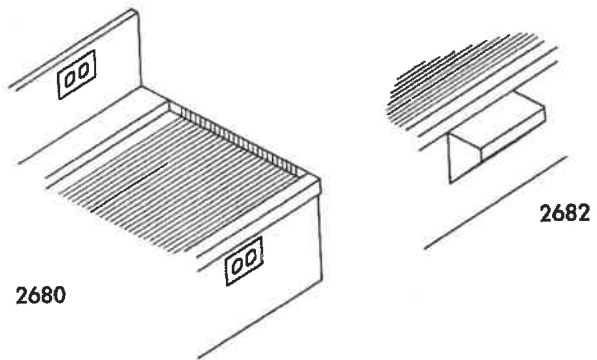

2680

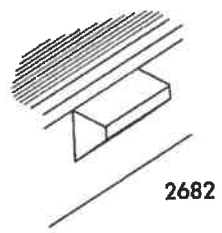

2682

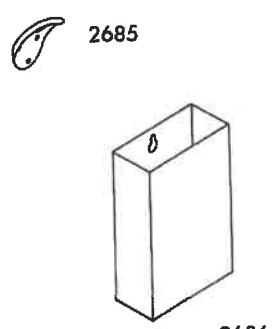

2685

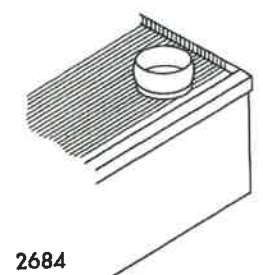

2684

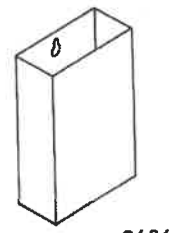

2686



2690

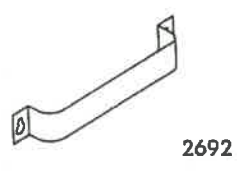

2692

UNIT NO.

- Duplex outlet in backsplash or apron 2680
- Dry waste chute (mounted in front apron) 2682
- Dry waste chute (installed in workboard surface, collar extends about 2" above workboard surface) 2684
- Chrome opener only 2685
- Chrome opener with stainless steel cap catcher 2686
- Towel ring 2690
- Towel bar installed (8" x 1 1/2") 2692
- Lock for sliding doors of cabinet base (per set of (2) doors) 2698

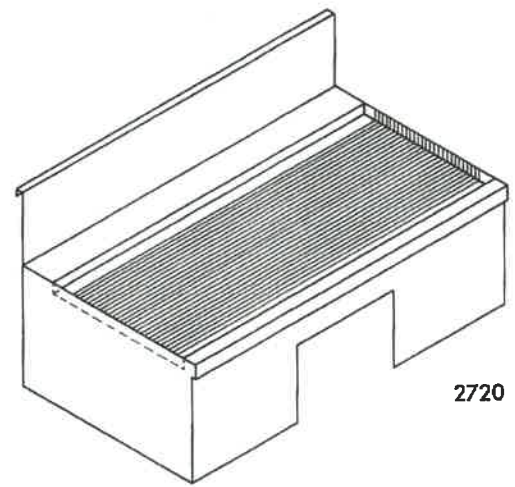

2720

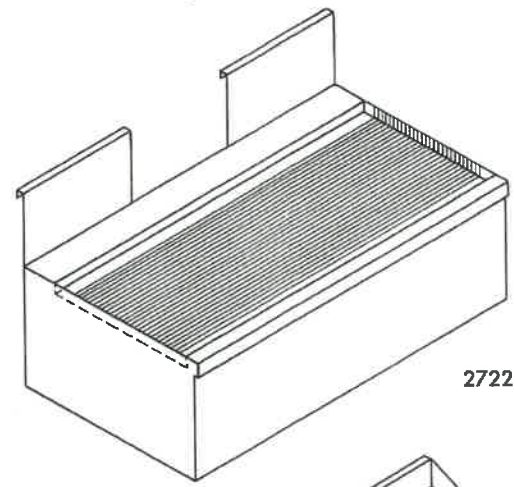

2722

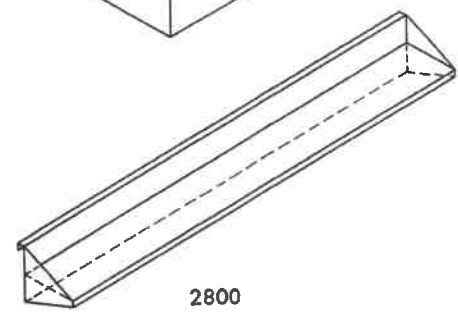

2724

UNIT NO.

- Apron cutout (up to 12" wide) 2720
- Backsplash cutout (up to 12" wide) 2722
- Backsplash cut down (minimum 3') 2724
- Hang-on backsplash shot glass storage shelf, removeable for cleaning. (Priced per foot) 2800



PERFECTION Equipment, Inc.

4259 Lee Avenue, Gurnee, Illinois 60031 Phone: 847-244-7200 Fax: 847-244-7205
 Website: www.perfectequip.com Email: sales@perfectequip.com

Toll Free: 800-356-6301



PERFECTA PF-22 and PF-19 Ice Chests and Accessories

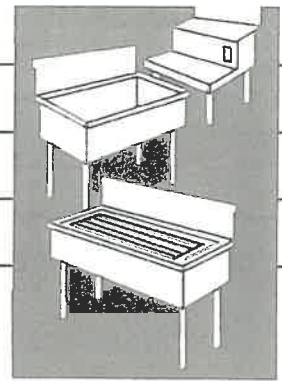

BUILT-IN ICE CHESTS-10" DEEP

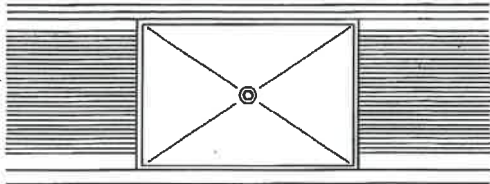

	UNIT NO.
18" Ice chest (16" x 16" x 10" deep) Ice capacity: 50 lbs.	2300
24" Ice chest (22" x 16" x 10" deep) Ice capacity: 80 lbs.	2305
30" Ice chest (28" x 16" x 10" deep) Ice capacity: 110 lbs.	2310
36" Ice chest (34" x 16" x 10" deep) Ice capacity: 140 lbs.	2315
42" Ice chest (40" x 16" x 10" deep) Ice capacity: 170 lbs.	2320
44" Ice chest (42" x 16" x 10" deep) Ice capacity: 200 lbs.	2325
48" Ice chest (46" x 16" x 10" deep) Ice capacity: 230 lbs.	2330

BUILT-IN ICE CHESTS-16" DEEP

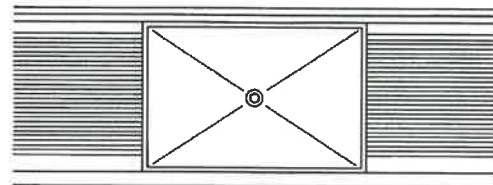

	UNIT NO.
18" Ice chest (16" x 16" x 16" deep) Ice capacity: 100 lbs.	2335
24" Ice chest (22" x 16" x 16" deep) Ice capacity: 160 lbs.	2340
30" Ice chest (28" x 16" x 16" deep) Ice capacity: 220 lbs.	2345
36" Ice chest (34" x 16" x 16" deep) Ice capacity: 280 lbs.	2350
42" Ice chest (40" x 16" x 16" deep) Ice capacity: 340 lbs.	2355
44" Ice chest (42" x 16" x 16" deep) Ice capacity: 400 lbs.	2360
48" Ice chest (46" x 16" x 16" deep) Ice capacity: 460 lbs.	2365
8" Circuit Cold Plate. Add "CP" to part number	2370



PERFECTION Equipment, Inc.

4259 Lee Avenue, Gurnee, Illinois 60031 Phone: 847-244-7200 Fax: 847-244-7205
Website: www.perfectequip.com Email: sales@perfectequip.com

Toll Free: 800-356-6301



FREE STANDING ICE CHEST-10" DEEP

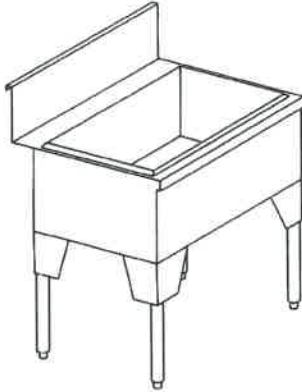

UNIT NO.

- 24" Long free standing ice chest.
Inner liner (22" x 16" x 10" deep)
Ice capacity: 80 lbs.2400
 - 30" Long free standing ice chest.
Inner liner (28" x 16" x 10" deep)
Ice capacity: 110 lbs.2410
 - 36" Long free standing ice chest.
Inner liner (34" x 16" x 10" deep)
Ice capacity: 140 lbs.2420
- 8" Circuit cold plate available. Add "CP" to part number.

FREE STANDING ICE CHEST-16" DEEP

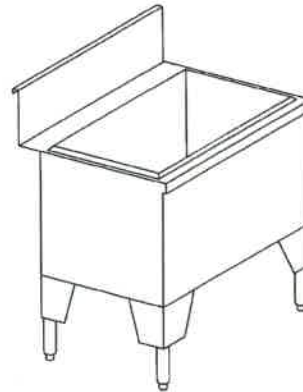

UNIT NO.

- 24" Long free standing ice chest.
Inner liner (22" x 16" x 16" deep)
Ice capacity: 160 lbs.2450
 - 30" Long free standing ice chest.
Inner liner (28" x 16" x 16" deep)
Ice capacity: 220 lbs.2460
 - 36" Long free standing ice chest.
Inner liner (34" x 16" x 16" deep)
Ice capacity: 280 lbs.2470
- 8" Circuit cold plate available. Add "CP" to part number.



PERFECTION Equipment, Inc.

4259 Lee Avenue, Gurnee, Illinois 60031 Phone: 847-244-7200 Fax: 847-244-7205
Website: www.perfectequip.com Email: sales@perfectequip.com

Toll Free: 800-356-6301



**ACCESSORIES FOR ICE CHESTS—10" DEEP
OR 16" DEEP**

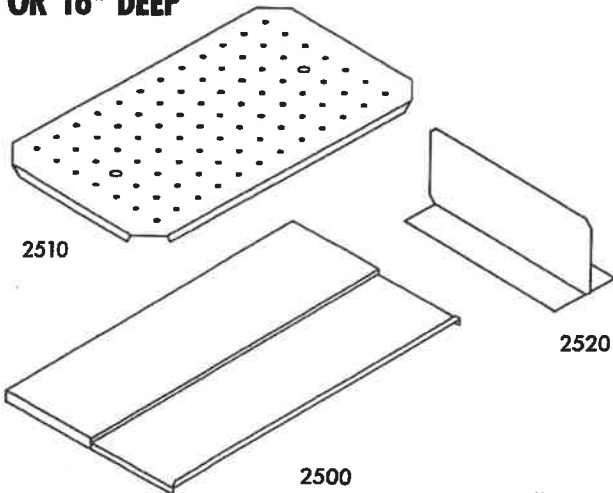

	UNIT NO.
18" Full sliding cover	2500
24" Full sliding cover	2501
30" Full sliding cover	2502
36" Full sliding cover	2503
42" Full sliding cover	2504
44" Full sliding cover	2505
48" Full sliding cover	2506
18" Perforated SS bottom plate (Should not be used with cold plate)	2510
24" Perforated SS bottom plate. (Should not be used with cold plate)	2511
30" Perforated SS bottom plate (Should not be used with cold plate)	2512
36" Perforated SS bottom plate (Should not be used with cold plate)	2513
42" Perforated SS bottom plate (Should not be used with cold plate)	2514
44" Perforated SS bottom plate (Should not be used with cold plate)	2515
48" Perforated SS bottom plate (Should not be used with cold plate)	2516
Ice Divider for 10" deep ice chest	2520
Ice Divider for 16" deep ice chest	2540

PASS THRU ICE CHESTS

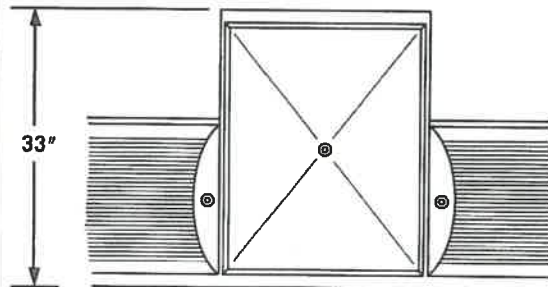

	UNIT NO.
18" x 10" deep	2545
24" x 10" deep	2546
30" x 10" deep	2547
36" x 10" deep	2548



PERFECTION Equipment, Inc.

4259 Lee Avenue, Gurnee, Illinois 60031 Phone: 847-244-7200 Fax: 847-244-7205
Website: www.perfectequip.com Email: sales@perfectequip.com

Toll Free: 800-356-6301



MISCELLANEOUS ACCESSORIES FOR ICE CHESTS



2554

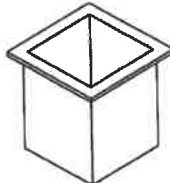

2555

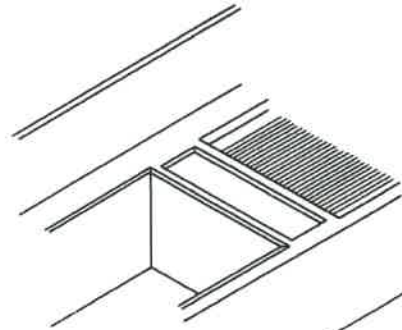

2556
(RUBBER CUPS NOT SHOWN)

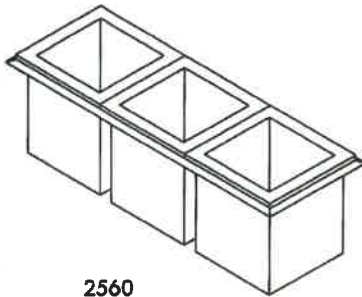

2560



2562

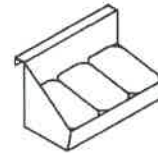

2573

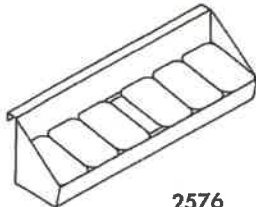

2576



2740

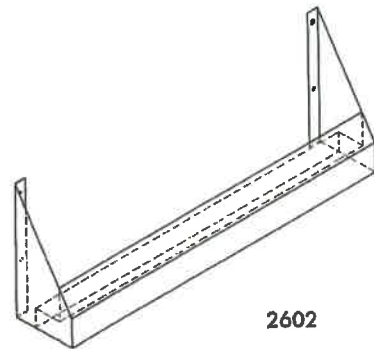

2602

	UNIT NO.		UNIT NO.
Rubber cups for bottle wells (round cup)	2554	12" Long slanted condiment section with three (3) cups . .	2573
Rubber cups for bottle wells, square 3 Max./channel	2555	24" Long slanted condiment section with six (6) cups	2576
Bottle well channels for rubber cups installed in workboard surface. Standard size—4 ⁵ / ₈ " x 14 ⁵ / ₈ " square holes for 3 rubber inserts/channel; 4 ¹ / ₂ " round holes for 3 rubber inserts/channel	2556	Single hang-on speedrail	2602
Bottle well insert with 6 rubber cups	2560	Single hang-on speedrail with locking cover	2604
Bottle well insert with 6 stainless steel cups	2562	Leg bracket. Used when ice chest is on the end of workboard lineup and when legs cannot be moved in to support workboard.	2740



PERFECTION Equipment, Inc.

4259 Lee Avenue, Gurnee, Illinois 60031 Phone: 847-244-7200 Fax: 847-244-7205
Website: www.perfectequip.com Email: sales@perfectequip.com

Toll Free: 800-356-6301



PERFECTA PF-22
Consultant Series
QUICK-POUR

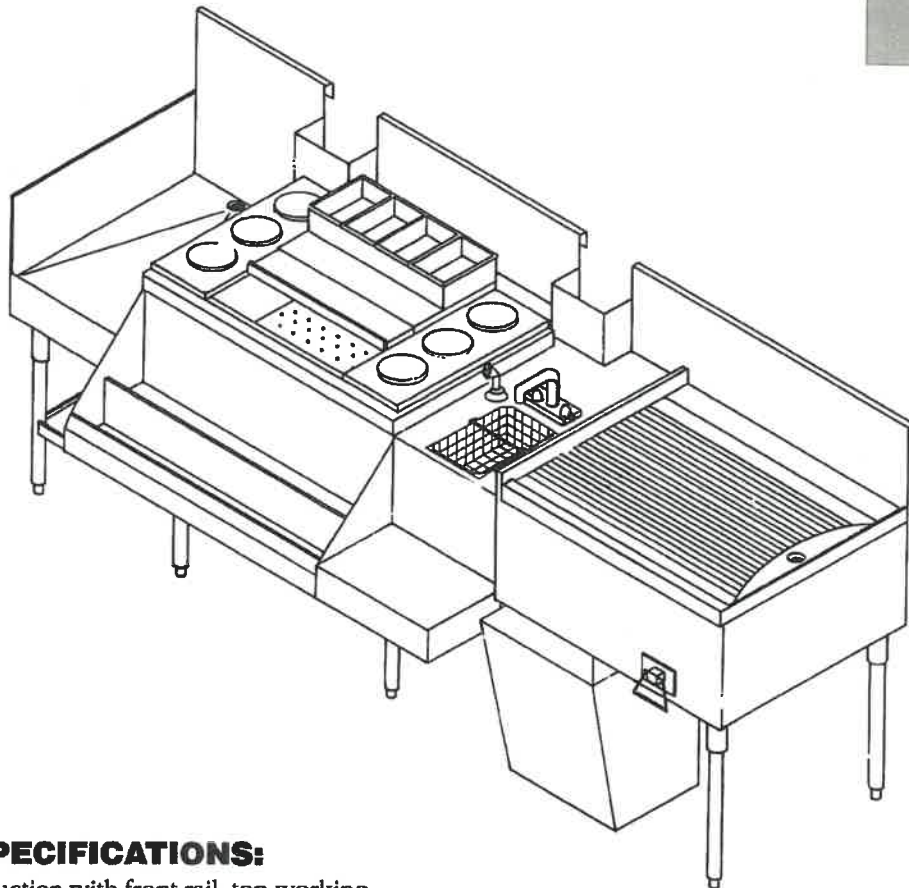
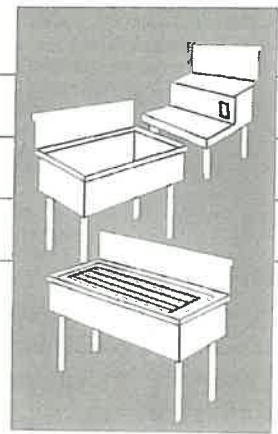

Model #QP-84

GENERAL SPECIFICATIONS:

- One-piece construction with front rail, top working surface and backsplash die-formed from one sheet of 18 GA. type 304 stainless steel
- Apron & both ends of 18 GA. type 304 stainless steel
- Corrugated areas are pitched to rinse tank or drain area
- All undersurfaces are mastic coated
- Mastic coated ice chest liner, fully insulated
- Corner support members & leg sockets are electrically welded into place
- Legs are 16 GA. stainless steel with adjustable stainless steel bullet feet
- Leg sockets are constructed of 16 GA. stainless steel with locking set screw, heliarc welded to 16 GA. stainless steel support channels.

Note:

Various sizes available in 6" increments. Minimum 12" on drainboard to accommodate stack-all glass rack. Minimum 9" on blender stand to accommodate 6" x 6" or 6" x 9" dumsink.



PERFECTION Equipment, Inc.

4259 Lee Avenue, Gurnee, Illinois 60031 Phone: 847-244-7200 Fax: 847-244-7205
Website: www.perfectequip.com Email: sales@perfectequip.com

Toll Free: 800-356-6301



QUICK-POUR QP-54

OPTIONS:

- Pair of bottlewell inserts #2562
- Stainless steel condiment tray with 3 wells #2573
- 6" x 6" or 6" x 9" dumpsink
- Lift out strainer basket
- Liquor or soda chase #2635
- Ice bin divider #2520
- Shot glass storage rack #2800
- Sealed in cold plate (30" ice chest) #CP
- Locking cover for speedrail
- Spray faucet
- Apron mounted dry waste chute #2682 (QP- 72 & QP-84 only)
- Bottle opener & cap catcher #2686 (QPB- 72 & QP-84 only)

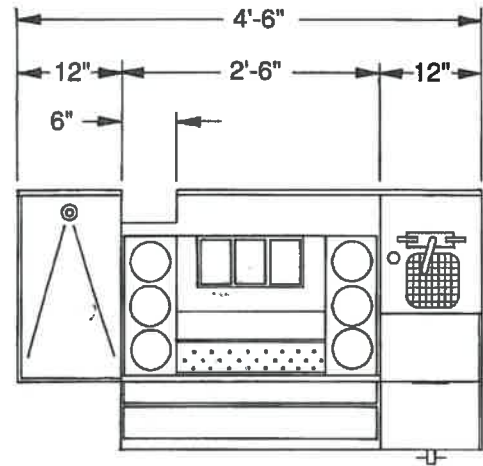

FEATURES:

- Recessed drainboard to accommodate 10" x 20" stack-all glass rack
- 30" ice chest with S/S cover and perforated false bottom
- Double step blender shelf with duplex outlet
- Towel ring
- Double speedrail
- Glass rack storage shelf

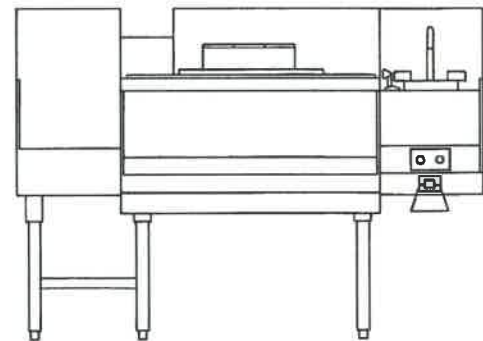
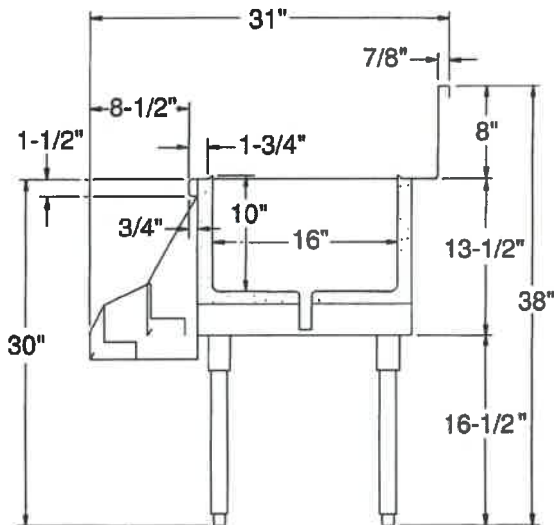

PERFECTION Equipment, Inc.

4259 Lee Avenue, Gurnee, Illinois 60031 Phone: 847-244-7200 Fax: 847-244-7205
 Website: www.perfectequip.com Email: sales@perfectequip.com

Toll Free: 800-356-6301



QUICK-POUR QP-60

OPTIONS:

- Pair of bottlewell inserts #2562
- Stainless steel condiment tray with 3 wells #2573
- 6" x 6" or 6" x 9" dumpsink
- Lift out strainer basket
- Liquor or soda chase #2635
- Ice bin divider #2520
- Shot glass storage rack #2800
- Sealed in cold plate (30" ice chest) #CP
- Locking cover for speedrail
- Spray faucet
- Apron mounted dry waste chute #2682 (QP-72 & QP-84 only)
- Bottle opener & cap catcher #2686 (QP-72 & QP-84 only)

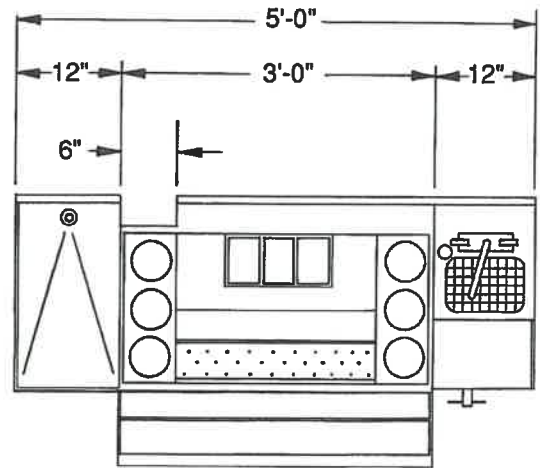

FEATURES:

- Recessed drainboard to accommodate 10" x 20" stack-all glass rack
- 36" ice chest with S/S cover and perforated false bottom
- Blender shelf with duplex outlet
- Towel ring
- Double speedrail
- Glass rack storage shelf

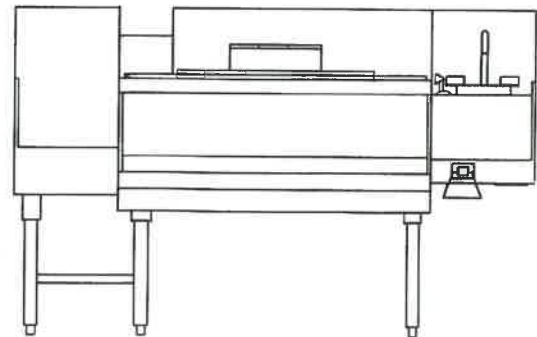
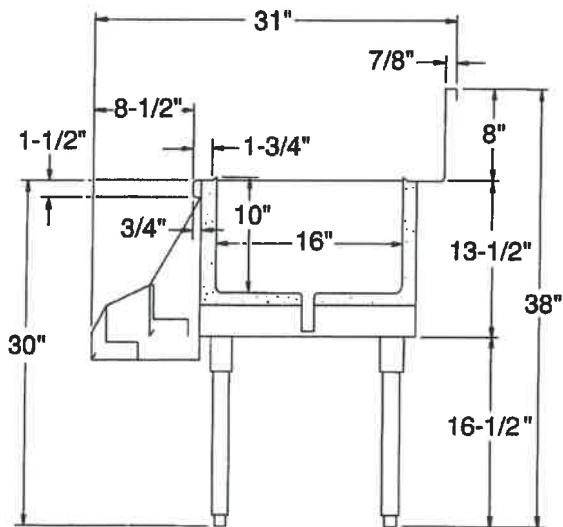

PERFECTION Equipment, Inc.

4259 Lee Avenue, Gurnee, Illinois 60031 Phone: 847-244-7200 Fax: 847-244-7205
 Website: www.perfectequip.com Email: sales@perfectequip.com

Toll Free: 800-356-6301

NSF

QUICK-POUR QP-84

OPTIONS:

- Pair of bottlewell inserts #2562
- Stainless steel condiment tray with 3 wells #2573
- 6" x 6" or 6" x 9" dumpsink
- Lift out strainer basket
- Liquor or soda chase #2635
- Ice bin divider #2520
- Shot glass storage rack #2800
- Sealed in cold plate (30" ice chest) #CP
- Locking cover for speedrail
- Spray faucet
- Apron mounted dry waste chute #2682 (QP- 72 and QP-84 only)
- Bottle opener & cap catcher #2686 (QPB- 72 & QP-84 only)

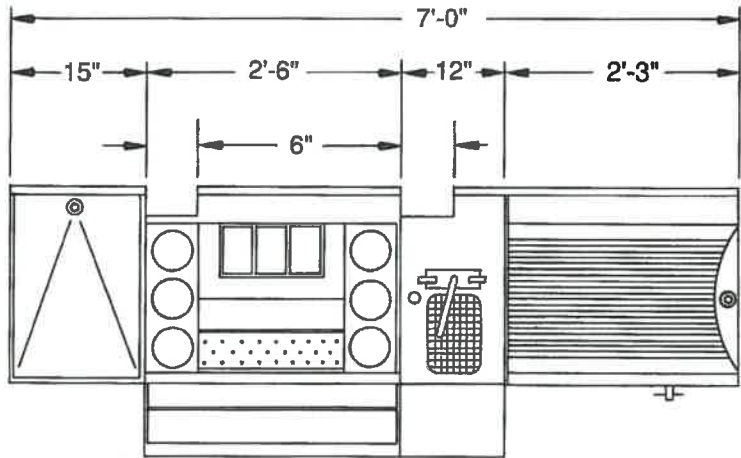

FEATURES:

- Corrugation drain
- Recessed drainboard to accommodate 10" x 20" stack-all glass rack
- 30" ice chest with S/S cover & perforated false bottom
- Blender shelf with duplex outlet
- Corrugated workboard
- Towel ring
- Double Speedrail
- Glass rack storage shelf

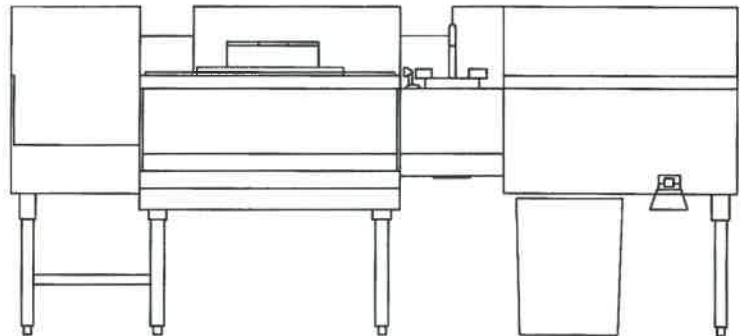
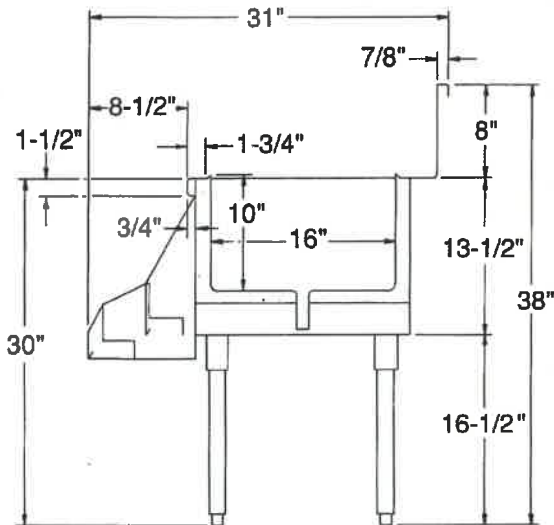

PERFECTION Equipment, Inc.

4259 Lee Avenue, Gurnee, Illinois 60031 Phone: 847-244-7200 Fax: 847-244-7205
 Website: www.perfectequip.com Email: sales@perfectequip.com

Toll Free: 800-356-6301



QUICK-POUR QPA-72

OPTIONS:

- Pair of bottlewell inserts #2562
- Stainless steel condiment tray with 3 wells #2573
- 6" x 6" or 6" x 9" dumpsink
- Lift out strainer basket
- Liquor or soda chase #2635
- Ice bin divider #2520
- Shot glass storage rack #2800
- Sealed in cold plate (30" ice chest) #CP
- Locking cover for speedrail
- Spray faucet
- Apron mounted dry waste chute #2682 (QP-72 & QP-84 only)
- Bottle opener & cap catcher #2686 (QPB-72 & QP-84 only)

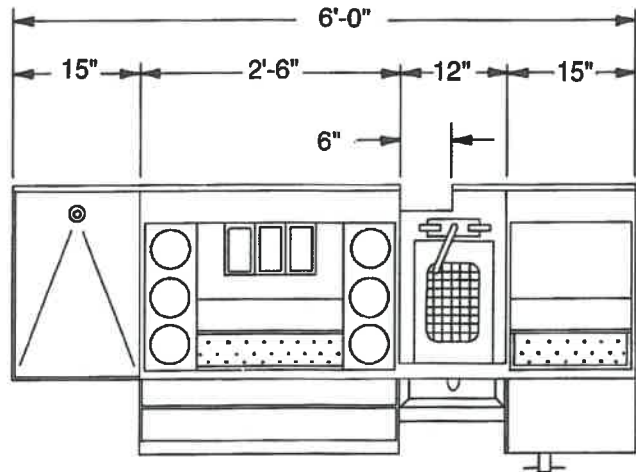

FEATURES:

- Recessed drainboard to accommodate 10" x 20" stack-all glass rack
- 30" ice chest with S/S cover and perforated false bottom
- Blender shelf with duplex outlet
- 15" ice chest with S/S cover & perforated false bottom
- Towel ring
- Double speedrail
- Glass rack storage shelf

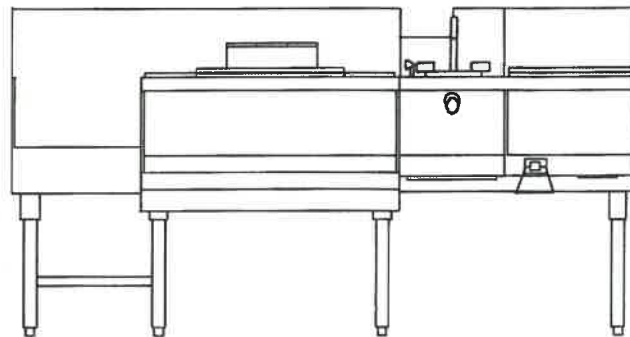
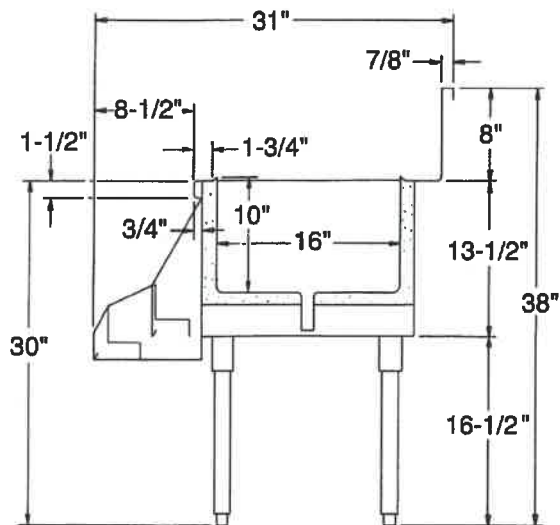

PERFECTION Equipment, Inc.

4259 Lee Avenue, Gurnee, Illinois 60031 Phone: 847-244-7200 Fax: 847-244-7205
Website: www.perfectequip.com Email: sales@perfectequip.com

Toll Free: 800-356-6301



QUICK-POUR QPB-72

OPTIONS:

- Pair of bottlewell inserts #2562
- Stainless steel condiment tray with 3 wells #2573
- 6" x 6" or 6" x 9" dumpsink
- Lift out strainer basket
- Liquor or soda chase #2635
- Ice bin divider #2520
- Shot glass storage rack #2800
- Sealed in cold plate (30" ice chest) #CP
- Locking cover for speedrail
- Spray faucet
- Apron mounted dry waste chute #2682 (QP-72 & QP-84 only)
- Bottle opener & cap catcher #2686 (QPB-72 & QP-84 only)

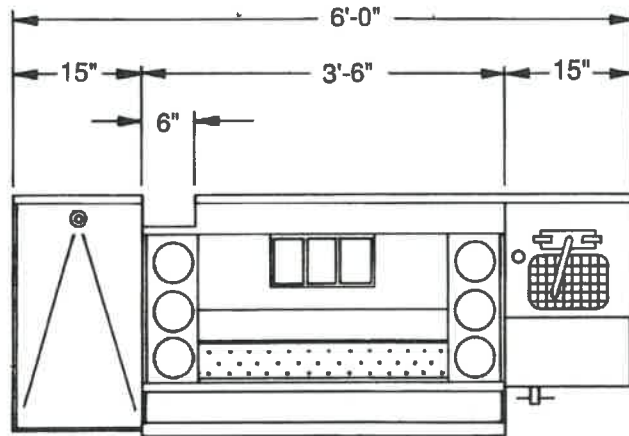

FEATURES:

- Recessed drainboard to accommodate 10" x 20" stack-all glass rack
- 42" ice chest with S/S cover and perforated false bottom
- Blender shelf with duplex outlet
- Towel ring
- Single speedrail
- Glass rack storage shelf

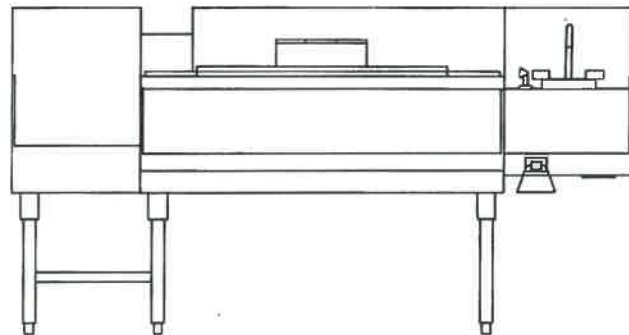
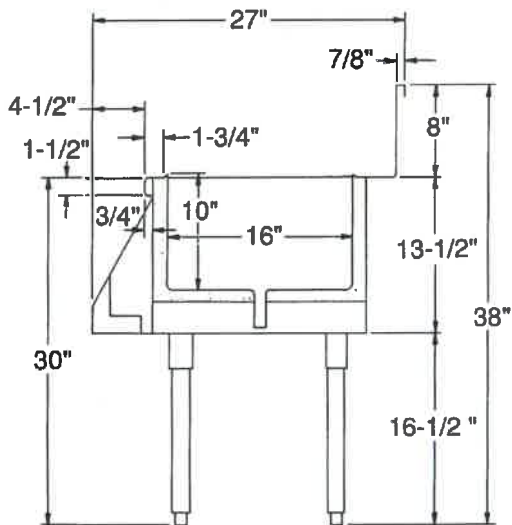

PERFECTION Equipment, Inc.

4259 Lee Avenue, Gurnee, Illinois 60031 Phone: 847-244-7200 Fax: 847-244-7205
 Website: www.perfectequip.com Email: sales@perfectequip.com

Toll Free: 800-356-6301



LOCKING SPEEDRAIL (STOWABLE)

MAXIMUM LENGTH = 36" (914mm)

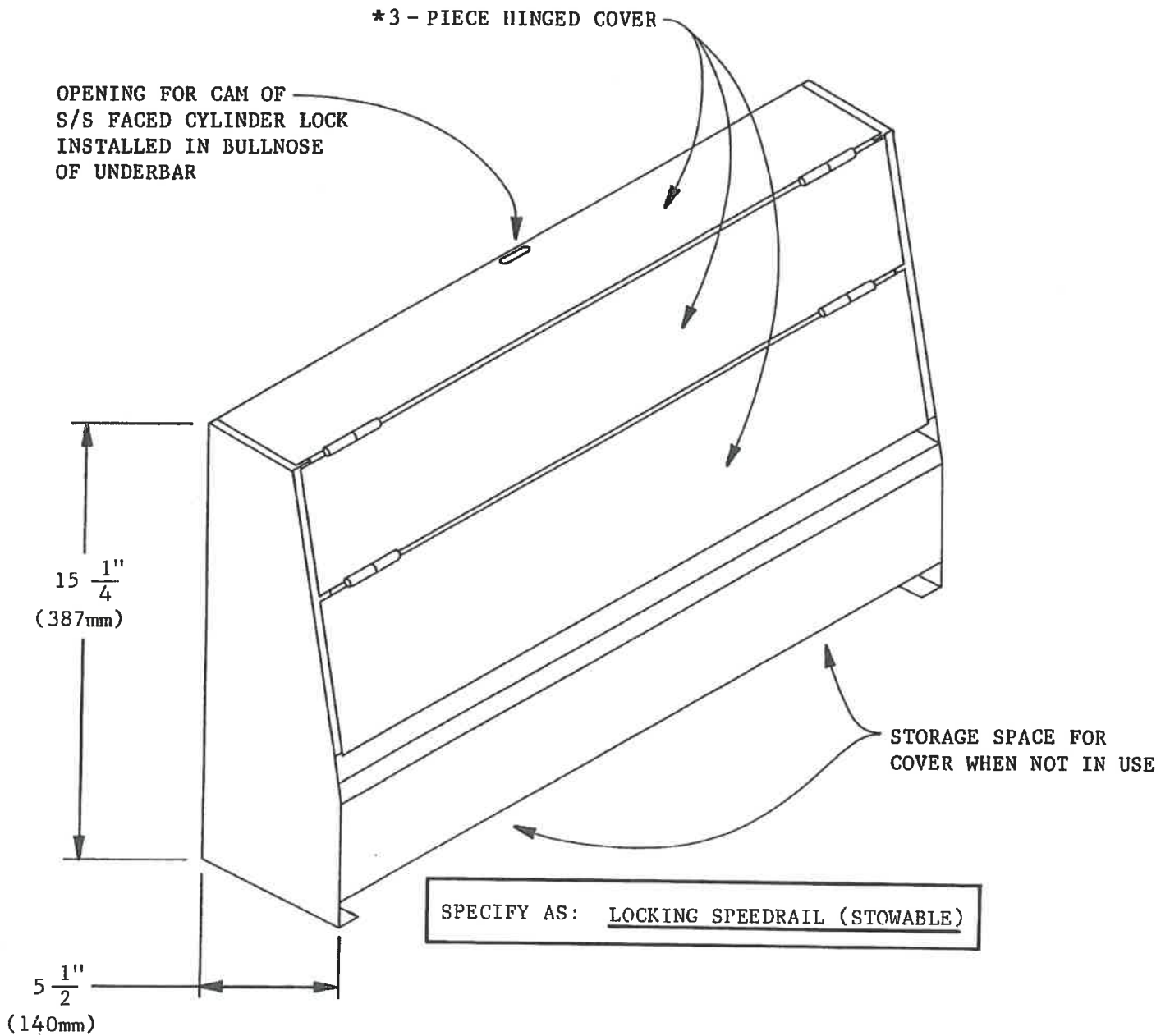

PERFECTION Equipment, Inc.

4259 Lee Avenue, Gurnee, Illinois 60031 Phone: 847-244-7200 Fax: 847-244-7205
Website: www.perfectequip.com Email: sales@perfectequip.com

Toll Free: 800-356-6301



LOCKING DOUBLE SPEEDRAIL (STOWABLE)

MAXIMUM LENGTH = 36" (914mm)

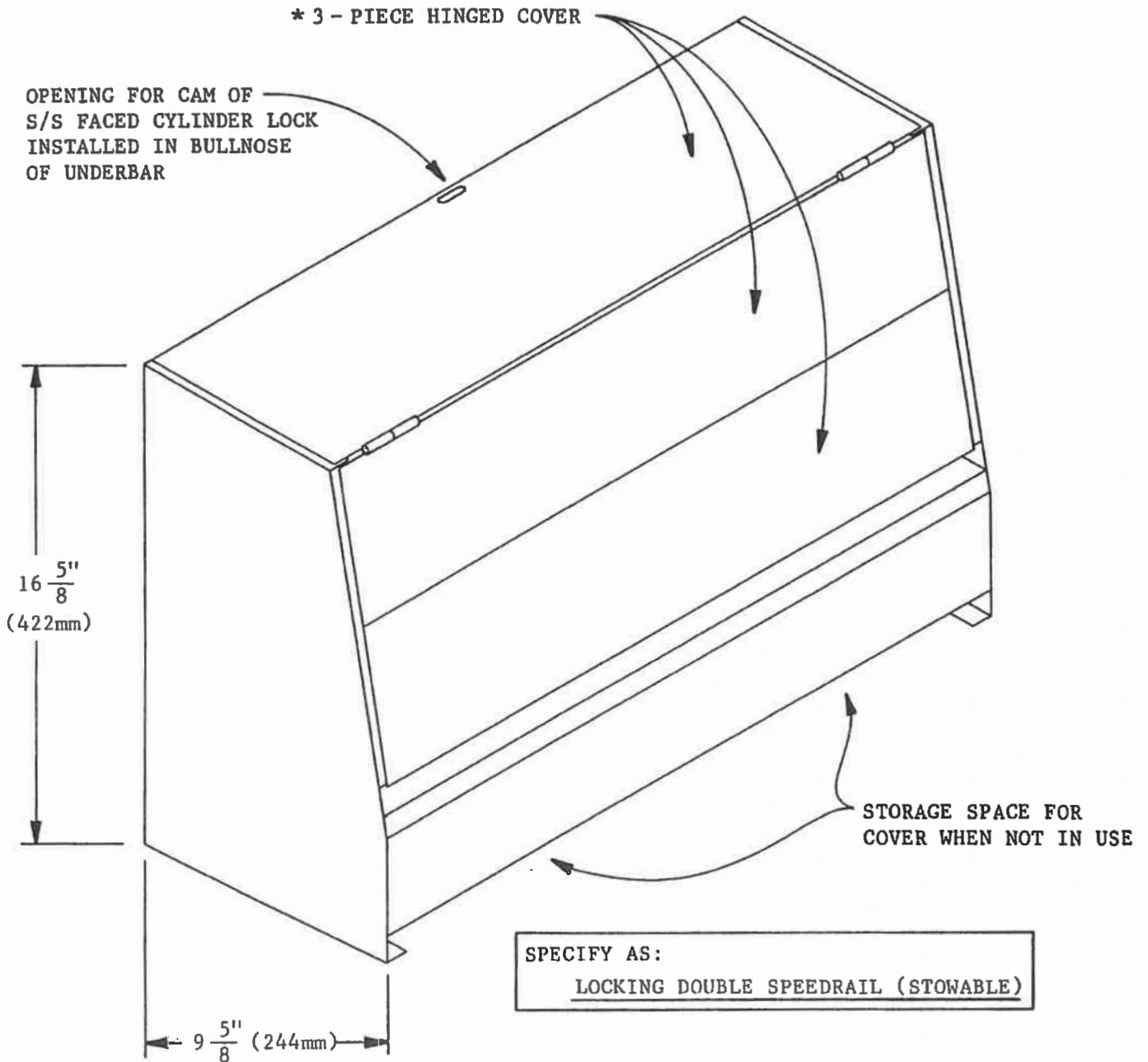

PERFECTION Equipment, Inc.

4259 Lee Avenue, Gurnee, Illinois 60031 Phone: 847-244-7200 Fax: 847-244-7205
Website: www.perfectequip.com Email: sales@perfectequip.com

Rev. 09/06/2019

Toll Free: 800-356-6301

