

UNDER – COUNTER CONDIMENT SYSTEM MODEL UC6P1TT

PERFECTION

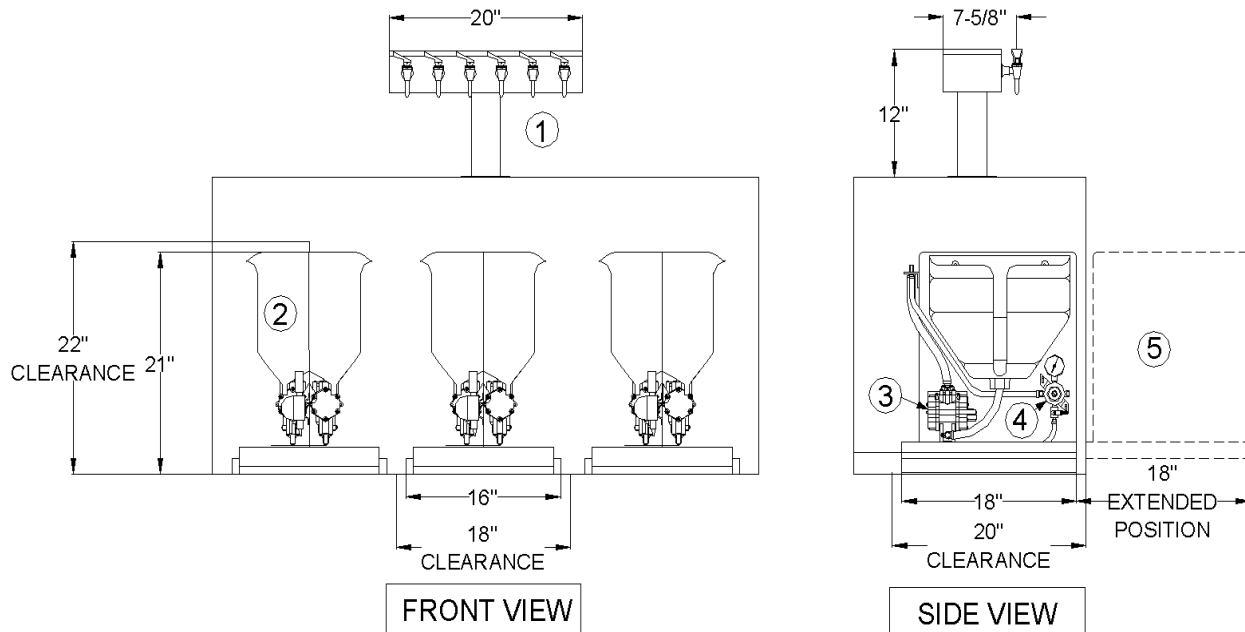

Perfection Equipment, Inc.
Perfecta Stainless Division



SECURE CRADLES TO CABINET FLOOR

NUMBERS REFER TO DRAWING

1. Stainless Steel 'T' TOWER with (6) Sureshot dispensing faucets (1)
2. Plastic 3-Gallon Product saddles (6)
3. Condiment Pump (6)
4. Low Pressure regulator (6)
5. Outline of Cradle in Extended Position

SYSTEM ALSO INCLUDES

Round Product Labels (6)

Bag Connectors (6)

Plastic Saddles, Pumps, Low Pressure Regulators, and Bag Connectors to be Pre-fabricated and mounted on (3) 2-product Stainless Steel slide out cradles with 18" slides. System comes complete with all necessary tubing and ancillary components for a complete installation. This includes a **Clean-In-Place** kit.

SERVICE AVAILABLE FROM A NATIONAL NETWORK

- Service Agencies Established and Trained
- Service Agencies Available Where You Need Them And When You Want Them



PERFECTION Equipment, Inc.

4259 Lee Avenue, Gurnee, Illinois 60031 Phone: 847-244-7200 Fax: 847-244-7205 Toll Free: 800-356-6301
Website: www.perfectequip.com Email: sales@perfectequip.com

Rev. 09/06/2019

