

**UNDER-COUNTER CONDIMENT  
SYSTEM MODEL UC1P1PT**

**PERFECTION**

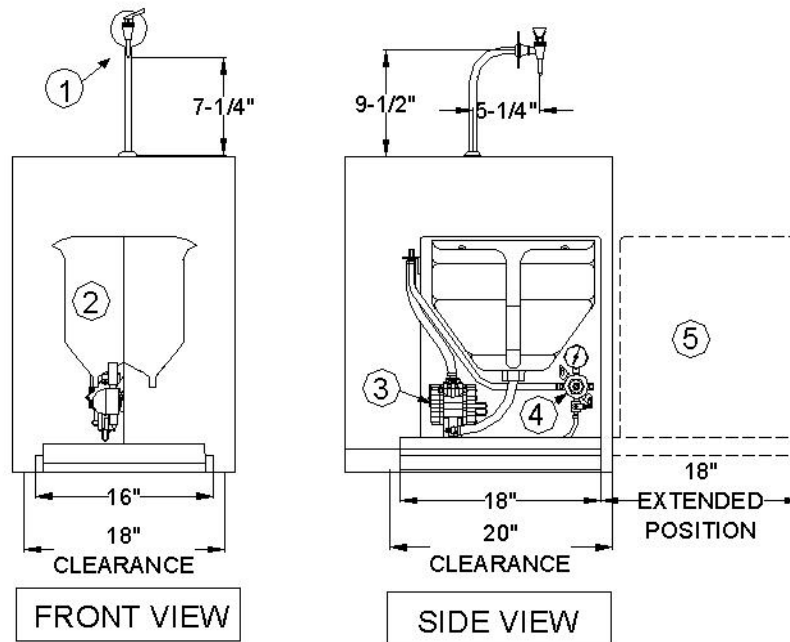

Perfection Equipment, Inc.  
Perfecta Stainless Division



**SECURE CRADLES TO CABINET FLOOR**

**NUMBERS REFER TO DRAWING**

1. PT-1 Dispenser with Sureshot dispensing faucet. (1)
2. Plastic 3-Gallon Product saddles (2)
3. Condiment Pump (1)
4. Low Pressure regulator (1)
5. Outline of Cradle in Extended Position

**SYSTEM ALSO INCLUDES**

- Round Product Labels (1)                      Bag Connectors (2)  
Manual Changeover Valve (1)

Plastic Saddles, Pump, Low Pressure Regulators, and Bag Connectors to be Pre-fabricated and mounted on a 2-bag Stainless Steel slide out cradle with 18" slides. System comes complete with all necessary tubing and ancillary components for a complete installation. This includes a **Clean-In-Place** kit.

**SERVICE AVAILABLE FROM A NATIONAL NETWORK**

- Service Agencies Established and Trained
- Service Agencies Available Where You Need Them And When You Want Them



PERFECTION Equipment, Inc.  
4259 Lee Avenue, Gurnee, Illinois 60031  
Phone: 847-244-7200 Fax: 847-244-7205 Toll Free: 800-356-6301  
Website: [www.perfectequip.com](http://www.perfectequip.com) Email: [sales@perfectequip.com](mailto:sales@perfectequip.com)

Rev. 09/06/2019

