

# BAG-IN-BOX SYRUP RACKS

# PERFECTION



Perfection Equipment, Inc.  
Perfecta Stainless Division



## FEATURES

- Meets all applicable N.S.F. requirements
- Long lasting 16 guage Steel Construction
- Galvanized Bag-In-Box Shelves sloped for easy removal of product
- Galvanized top shelf to accomodate beverage system
- Upright posts and shelf supports finished in No-Mar Polycoat
- Side mounting panels for Bag-In-Box pumps
- Adjustable stainless steel feet

(Assembly required)

## OPTIONS

- Stainless steel Bag-In-Box shelves
- Stainless steel top shelf

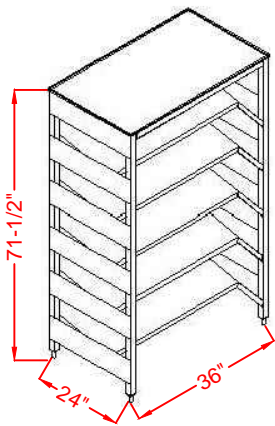

**MODEL**  
**PE-10-BIB-TS**  
Capacity (10)  
Bag-In-Box cartons

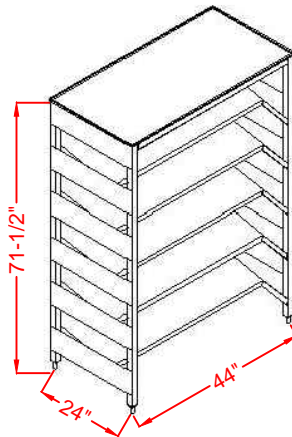

**MODEL**  
**PE-15-BIB-TS**  
Capacity (15)  
Bag-In-Box cartons

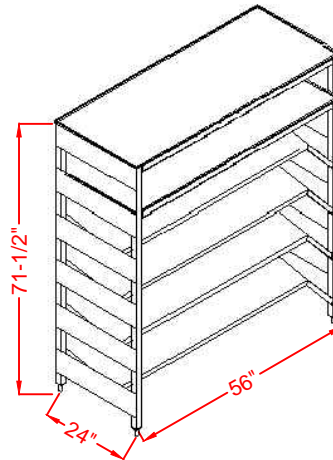

**MODEL**  
**PE-16-BIB-2TS**  
Capacity (16)  
Bag-In-Box cartons  
Additional top shelf for  
air compressor

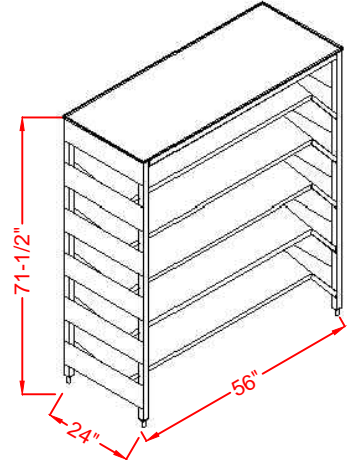

**MODEL**  
**PE-20-BIB-TS**  
Capacity (20)  
Bag-In-Box cartons

## SERVICE AVAILABLE FROM NATIONAL NETWORK

- Service Agencies Established and Trained
- Service Agencies Available where You need them and when You want them



**PERFECTION Equipment, Inc.**

4259 Lee Avenue, Gurnee, Illinois 60031, Phone: 847-244-7200, Fax: 847-244-7205, Toll Free: 800-356-6301  
Website: [www.perfectequip.com](http://www.perfectequip.com) Mail to: [sales@perfectequip.com](mailto:sales@perfectequip.com)

Rev. 09/06/2019

