

BACK OF HOUSE FAST FILL SYSTEM MODEL PE-BOH-1

PERFECTION

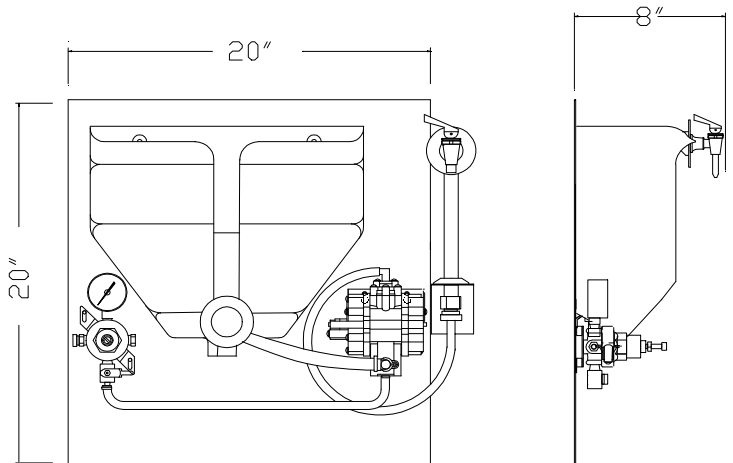

Perfection Equipment, Inc.
Perfecta Stainless Division

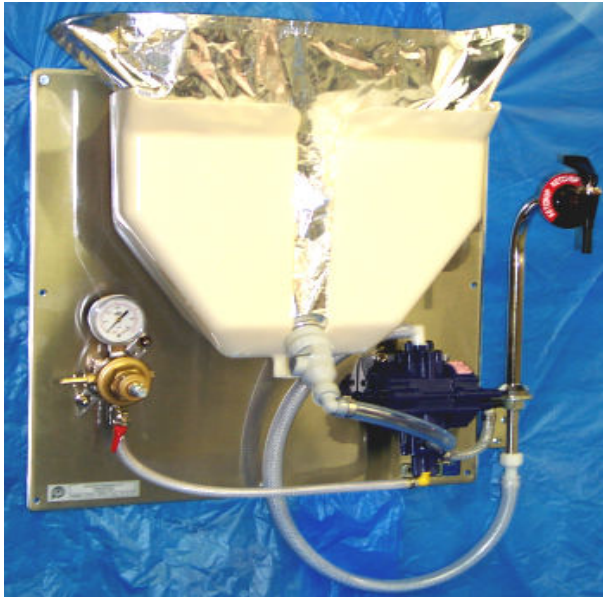

FEATURES

- 1- PT-1 Stainless Steel Pedestal Tower with Sureshot Valve / Optional High Flow
- 2- Accommodates 3-Gallon Bag-In-Box Format.
- 3- Approximately 98% Evacuation From Product Bag.
- 4- Flow Rate @ 65psi = 3.2 OZ. / Second @ 30psi = 2.2 oz. / Second

SYSTEM ALSO INCLUDES

Bag Connector, Plastic Saddle, Pump, and LP Regulator. Dispenser to be Pre-fabricated and mounted to the Stainless Steel Wall Plate. System comes complete and ready to mount to the wall. System includes a **Clean-In-Place Kit**.

For Connection to Remote CO₂ Source (by others). High Pressure Regulator Optional

SERVICE AVAILABLE FROM A NATIONAL NETWORK

- Service Agencies Established and Trained
- Service Agencies Available Where You Need Them And When You Want Them



PERFECTION Equipment, Inc.

4259 Lee Avenue, Gurnee, Illinois 60031 • Phone: 847-244-7200 • Fax: 847-244-7205 • Toll Free: 800-356-6301
www.perfectequip.com • sales@perfectequip.com

Rev. 09/06/2019

