

**MODEL UC2P2PT-CT34**  
**MOBILE CONDIMENT CART**  
**FOR ELEMENTARY SCHOOLS**

**PERFECTION**



Perfection Equipment, Inc.  
Perfecta Stainless Division



**FEATURES**

- 2-Product PT-1 Dispensers
- 6 Gallon Capacity (Two 3-Gallon Bags)
- Two Locking Casters - Two Fixed Casters
- All Stainless Steel Construction
- Round Product Labels (2)
- Bag Connectors (2)
- Plastic Saddles, Pump, Low Pressure Regulators, and Bag Connectors to be Pre-Fabricated and Mounted on Stainless Steel Fixed Panel.
- System comes complete with all necessary tubing and ancillary components for a complete installation.
- This includes a **Clean-in-Place** kit

Shown with optional Napkin Dispenser, Kondi-Keeper® & Souffle' Cup Dispenser

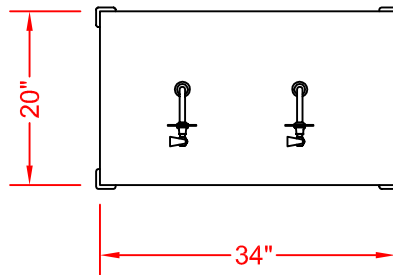

**OPTIONS**

- Napkin Dispenser
- Kondi-Keeper®
- Souffle Cup Dispenser

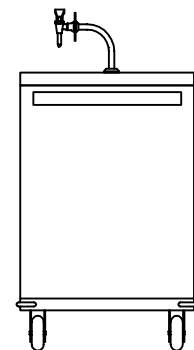
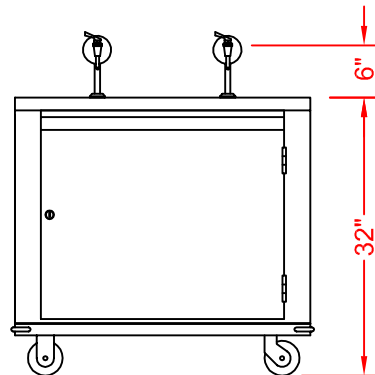
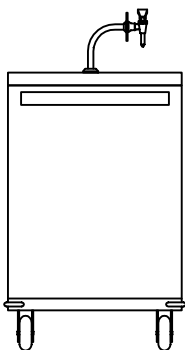

**SERVICE AVAILABLE FROM NATIONAL NETWORK**

- Service Agencies Established and Trained
- Service Agencies Available where You need them and when You want them



**PERFECTION Equipment, Inc.**

4259 Lee Avenue, Gurnee, Illinois 60031 Phone: 847-244-7200 Fax: 847-244-7205  
Toll Free: 800-356-6301 Website: [www.perfectequip.com](http://www.perfectequip.com) Email: [sales@perfectequip.com](mailto:sales@perfectequip.com)



Rev. 09/06/2019